

HITECH METAL FORMING

The Edge Of Innovation

Your Partner
for Engineering
Services & Solutions

- Scaffolding & Formwork Systems
- Waste Management Systems
- Facade Access Solutions
- Access & Lifting Solutions
- Construction Material & Equipment
- Projects Requirement
- Engineering Services

**COMPANY
CATALOGUE**

2024 / 2025

🌐 www.hitechmf.com

Your Partner For Engineering Services and project Requirements





INDEX

TITLE	.PAGE NO
Who we Are	5
FORMWORK & SCAFFOLDING SYSTEMS	7
LIGHT AND ALUMINUM SCAFFOLDS	17
TABLE FORMWORK	19
ADJUSTABLE COLUMN FORMWORK	24
PROPS	26
FORMWORK ACCESSORIES	30
FAÇADE ACCESS SOLUTIONS	34
FAÇADE CLEANING SOLUTIONS	45
FAÇADE INSTALLATION SYSTEMS	46
ACCESS EQUIPMENT SOLUTIONS	47
DOCK LEVELERS & LIFTING TABLE PLATFORMS	51
ROLLER SHUTTER DOORS	52
GARBAGE CHUTES AND WASTE SYSTEMS	53
PORTA CABINS	58
BAR BENDING AND CUTTING MACHINES	62
GRP / CTP MODULAR WATER TANK	63
CABLE TRAY MANAGEMENT SYSTEM	64
MANHOLE COVER	65
OUR PARTNERS	68

Who we are

Hitech Metal Forming and Services is Company with main office in Ajman , UAE, Branches in Jordan and Qatar . Our company is Specialized in offering and its distribution of world class product lines to variety of areas such as distribution and manufacturing of scaffolding materials. Access equipment , utilities and construction Materials .We are engage mainly in the field of Construction. We are operating throughout the Gulf Area and Middle East Specialized supplying projects with engineering products and demands.

Our Hitech Team provides full design and calculation services for any project requirement, to the latest industry codes of practice. “committed to innovation and integrity in design, quality and safety in manufacturing” “dedicated to excellence through quality performance, for the mutual long-term success of our customers and ourselves.”

Vision

Hitech Metal Forming and Services is dedicated to becoming the industry’s preferred supplier for the of scaffolding materials. We are committed to :

- 1- Innovation and integrity in design.
- 2 - Quality ,and service excellence, time to delivery and competitive project values .

Mission

Our mission is to be a world-class Supplier of metal fabricated products and services. We believe in the development of highly skilled team members committed to continuous improvement. We stride to:

- 1- Provide all requirements within reasonable time, cost and client satisfaction
- 2 - Continuously improve our performance in the construction site demands
- 3- Follow up all HSE and industry requirements

Values

We value:

- Our people
- Customer Satisfaction
- Accountability
- Integrity
- Hard Work
- Trust & Loyalty
- Confidence
- Good Management



. Quality and HSE Management

Our quality management system provides for:

- Materials testing
- Statistical sampling and work-in-progress tests
- Finished product evaluation

Customers may request performance charts and detailed inspection reports.

The health and safety of our production staff and site visitors, and the integrity of our environment is assured through our HSE management system.

This includes:

- Compliance with ISO standards
- The use of, and strict controls over PPE
- Incident reporting and investigation

. Our Range Of Products

1- Scaffolding, Support Systems and Formwork Material consisting of :

- wall formwork and accessories
 - Column Formwork and accessories
 - Slab and Beam support
 - Props and Push – Pull Props
 - Special and Customized formwork systems
 - Climbing System
 - Circular shuttering
 - Scaffold Tubes and Fittings
- 2- Access support system .
- 3- Wall form work and accessories .
- 4- Light weight scaffolding.
- 5- Aluminum and wooden ladders.
- 6- Props and push pull props Scaffold tubes and fittings.
- 7- Aluminum mobile towers .
- 8- Access Equipment
- 9- Garbage Chute Systems
- 10- Carbon Fiber for construction
- 11- Industrial Equipment
- 12- Construction Equipment
- 13- Construction Materials

FORMWORK & SCAFFOLDING SYSTEMS

- Slab Support & Decking System
- Special Formwork System
- Support Scaffolding
- Column Formwork
- Vertical Wall Shutter Formwork
- Circular System
- Access Scaffolding



SLAB SUPPORT & DECKING SYSTEM

CUPLOCK SYSTEM



CUP LOCK SYSTEM PRODUCT DESCRIPTION

Cup lock System mainly used for formwork to support structures, is a multi-purpose steel scaffold system suitable for providing general access and supporting vertical loads. Its high leg load and wide range of components gives the Cup lock System the capacity to tackle virtually any soffit support application with a cost-effective solution. The Cup lock System's key feature is its unique node point which allows up to 4 horizontals to be connected to a vertical in a single fastening action making it probably the fastest and safest system available. The comprehensive range of Cup lock System components allows it to be used for various construction applications. It can be used to create a wide range of support structures, access scaffolds, staircase towers, circular scaffolds, loading towers and mobile towers.

CUP LOCK SYSTEM FEATURES OVERVIEW

- Unique leg node point : accepts 4 ledgers, four horizontals can be fastened at one time with firm clamping action of top cup making the joint rigid
- Systemized bracing
- The Cup lock System incorporates components for access cantilever and internal or external drop beams
- Drop Forged Parts
- Early Striking Option
- Multiple decking options can be used efficiently : steel beams decking (infill beams and decking beams) , timber beams decking (H20, LVL, traditional timber) or Aluminum beams decking
- Lightweight system for access purposes
- High number of reuse cycles
- Finish options available are galvanized finish or painted finish
- Standard health and safety protection components offered

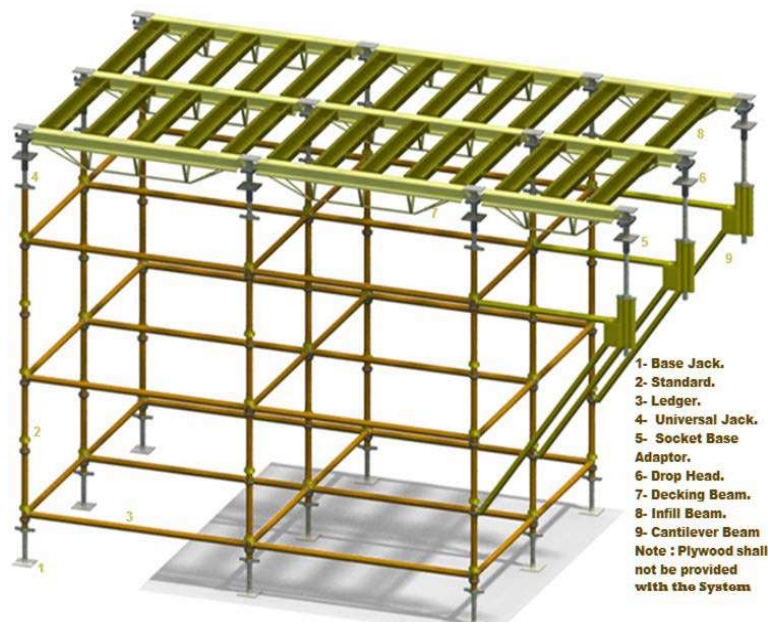

CUP LOCK SYSTEM ADVANTAGES AND BENEFITS

- Cup lock System is usable as an access or load bearing system suitable for all types of structures:
- commercial, residential and infrastructure.
- The adaptability of the Cup lock System to any slab thickness, height or layout makes it a well known and most commonly used system by contractors for both straight or curved structures on the construction site.
- Drop forged parts of the Cup lock System provide high durability and safety in the toughest construction environments.
- Early striking option makes the Cup lock System one the most economical systems for construction sites, due to it providing a technique for the formwork to be removed 3 to 4 days after pouring a slab, but the supporting structure of scaffolding or props remains undisturbed until the concrete is strong enough to support its own weight over its full span.
- The Cup lock System is reusable with little waste and low maintenance over many construction cycles to be a champion for sustainability in use.
- Crane time can be optimized since basic assembly of Cup lock System is possible with minimal crane use as components can be manually handled.
- No loose components in the Cup lock System allow for fast erection with simplicity in assembly, dismantling and storage. Other than improving time efficiency on site, the Cup lock System reduces the requirement for skilled labor.
- Guard rails and Edge protection is normally fixed after or during the assembly of the system units to meet with standard health and safety norms.
- Cup lock System is versatile for use in construction, shoring, access, demolition or maintenance projects of any type with a proven safety and performance record



1
Fix ledger blade ends into lower cup



2
Position the upper cup over the top end of ledger blades



3
Rotate the top cup with hammer to lock the blade ends



4
A simple and secure connection is achieved



SCAFFOLD COMPONENTS



Drop Head



Cup Lock System



Swivel Couplers



Double Couplers



Beam Support



Spigot Connector



Base Plate



Fixed U Head



Drop Head Socket Plate



Cantilever Frame



Ledgers



Standards



Base jack



Adjustable U Head



Universal jack

CUP LOCK SCAFFOLD COMPONENTS DESCRIPTION

1- Standards (Vertical)

The standards are economical and can match any propping access application where they allow support or access when needed. , the upper cups can be moved, while the lower cups are welded into position. Spigot joints can be attached to the holes, drilled in the standards and if needed, a retaining pin is utilized to prevent movement. The covers are cast under the strictest guidelines to ensure durability under the rough condition of site handling. The standards are available in 0.5 m to 3.0 m sizes. Spigot connectors are provided for final assembly



2- Ledgers (Horizontal)

Highest quality steel tubes are used for the ledgers. To avoid any potential damage they have identical forged ends with a minimum of projection. Ledgers are available in sizes ranging from 0.60 m up to 2.50 m.

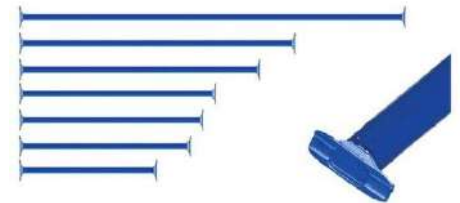

3- Cantilever Elements

A- Cantilever Frame (CF) & Cantilever Beam Frame (CBF)

To provide extra support at the edge of construction, especially slab edge from work, the cantilever frame (CF) & cantilever beam frame (CBF) can be attached directly to the vertical at the node points. In these frames universal jacks can be fitted to hold the various supports, fork heads and drop heads at a 1.2 m, 1.25 m or 1.3 m span respectively.

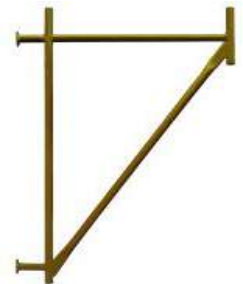

B-Beam Bracket

Beam bracket eliminates full height propping to beam formwork by locating on to slab support vertical as shown. The beam bracket the surrounding system structure, thus reducing excessive strain on all component distributes the load throughout .



4. Universal Jack

Universal jacks allow differences in height to be maintained. The base jacks like the universal jacks are either hollow or solid with deep threads. Easy adjustments can be made with the universal jacks special spindles.



5. Base Jack

The base jacks are made of the highest quality steel, and are designed with deep threads and strong handles.

DECKING SYSTEM COMPONENTS

The Decking System is designed to support a variety of bay sizes with a maximum load of 40 kN on any supporting leg. For maximum economy, the rapid strike drop head offers the facility for early striking of the decking system. When the support plate on the drop head remains in position to support the slab, the decking beam can be dismantled and reassembled elsewhere to enable greater utilization of the equipment.

This Decking system is ideally suited for construction of reinforced concrete suspended slabs, with plywood shuttering, and incorporates the benefits of early striking. Large grid sizes of up to 2.5 x 1.8 m ensures speedy erection and different sizes of primary and secondary beams can give a range of twelve support modules.

A. Decking Beam

The decking beams are designed with a very wide top flange thereby reducing maintenance costs by increasing the lifespan of the plywood. The decking beams are available in all the standard sizes, but any special sizes can be constructed. The decking beam is used with the drop head to form the decking system made from sheeted components and available in lengths 1.2 m , 1.8 m and 2.5 m

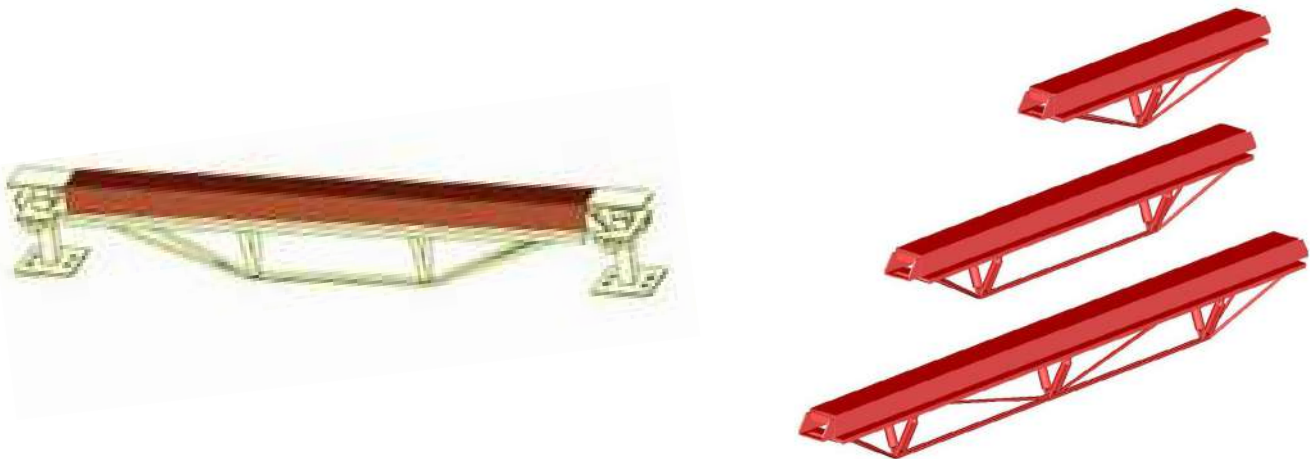

B. Infill Beam

The infill beams span between the decking beam to support the plywood , All standard sizes from 0.50 m up to 1.75 m are manufactured, as well as any special sizes upon request. They have a wide top which gives more support for the plywood. They are manufactured from sheeted components .



DECKING SYSTEM COMPONENTS

C. Drop Head

The most important part of shuttering is the drop head. Made with an extra-strong steel wedge, the drop heads allow the beams, infill's and panels to be lowered at a hammers stroke. The wedge is specially constructed to endure repeated strokes of the hammer. Drop head offers the facility of early striking of the formwork , the wedge plate on the drop head can be conveniently struck so that the drop head remains in position to support the slab, but the decking beam can be dismantled and assembled on next location enabling optimum utilization of the formwork



D Socket Base Adaptor

It Provides a base for the universal jack , also connect universal jack to the drop head.



E. H20 timber Beam

- The H 20 Timber formwork Beams are the basis of many formwork systems and have wide range of uses
- The H20 beams is familiar name all over the world and is the right choice of any application
- The H 20 Beams are made of wooden material to European standard .



F. Aluminum Beams

- The benefit of aluminum formwork products compared with their steel and timber equivalent have had a major impact on formwork practice . The light weight of Aluminum beams which can weight as little as one third of their steel equivalent opens the way to greatly increased site acceptance and productivity.
- The corrosion resistance of Aluminum beams insures along maintenance free life further extended by the fact that it cannot be easily cut up on site like timber beams.

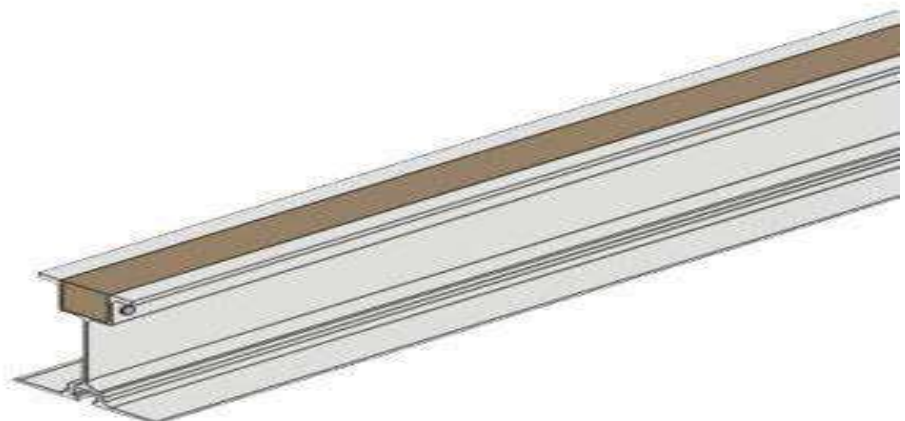

CUP LOCK COMPLETE DECKING SYSTEM ASSEMBLY

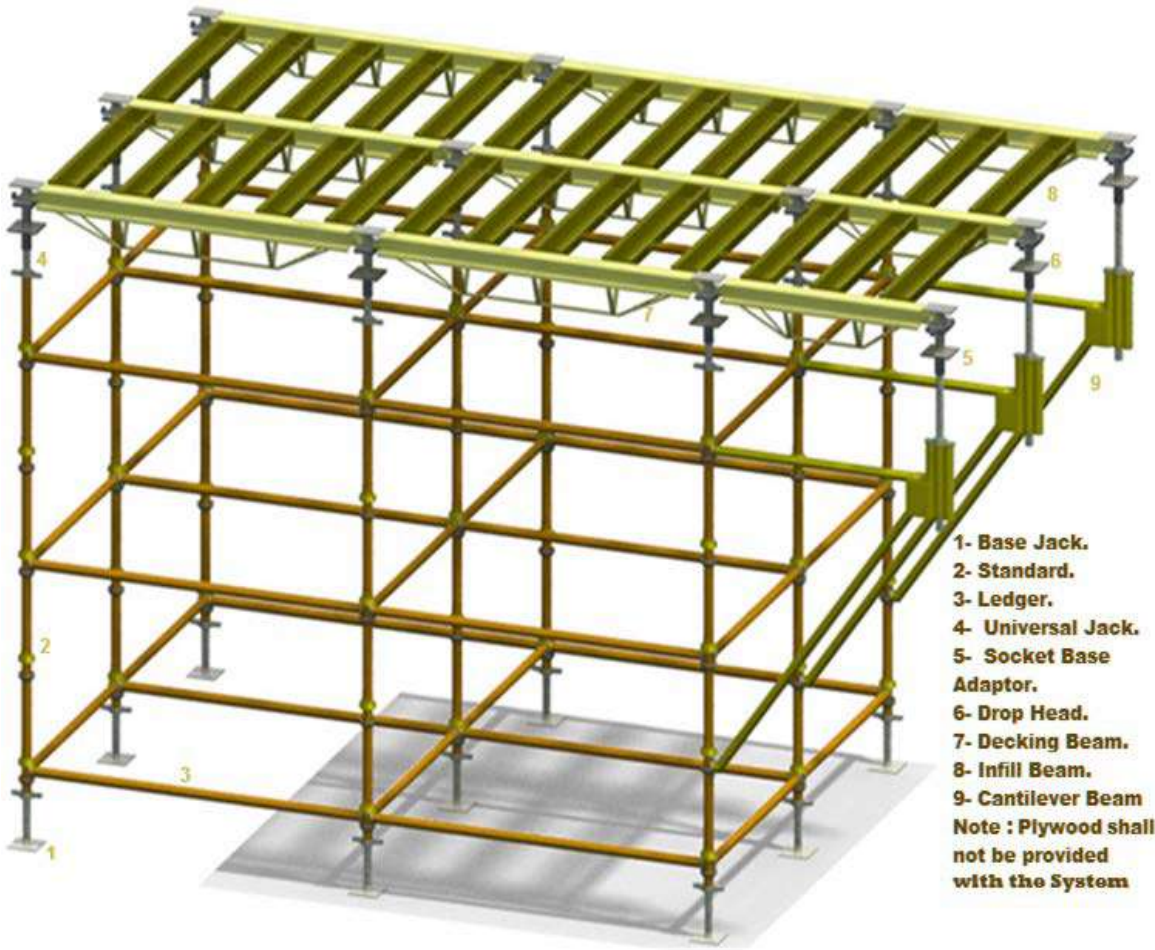

- 1- Base Jack.
 - 2- Standard.
 - 3- Ledger.
 - 4- Universal Jack.
 - 5- Socket Base Adaptor.
 - 6- Drop Head.
 - 7- Decking Beam.
 - 8- Infill Beam.
 - 9- Cantilever Beam
- Note : Plywood shall not be provided with the System**

CUP LOCK STAIRCASE

Assembly

- Lay out the equipment in approximately the required positions in the correct location.
- Adjust the Base Jacks, allowing a minimum of adjustment.
- Adjust the jacks to ensure that the structure is level.
- Add the initial Standards and Ledgers.
- Place first Standard over a Jack, and hold in position whilst the other operators locate ledgers.
- Set up the base grid of Standards and Ledgers based on design bay.
- Locate Face Bracing in both end bays and one side of the central .
- Add temporary working platforms, of minimum 60 cm width.
- Position first staircase unit.
- Install temporary working platform.

Cup lock Public Access Staircase Tower is a heavy duty access structure that can support the weight and horizontal forces of large numbers of persons.

The Cup lock Staircase needs little maintenance during use, but the structure should be examined at least once every 5 days. At all times care should be exercised when ascending or descending the structure, especially when there are other people on the structure.



LIGHT AND ALUMINUM SCAFFOLDS

Light Scaffolds



Aluminum Scaffold Towers



FLEX SYSTEM USING PROPS

Flex System is a cost effective and flexible soffit formwork.

It is suitable for most Slab Thicknesses and heights.

The use of H20 Beam or Aluminum Beam provides the system more flexibility because of its light weight.

Flex System has few numbers of items as it uses the same materials for Primary and Secondary Beams.

System Components

- Props.
- Fork Head.
- H 20 Beam or Aluminum (Main).
- H 20 Beam Aluminum (Cross).
- Tripod.

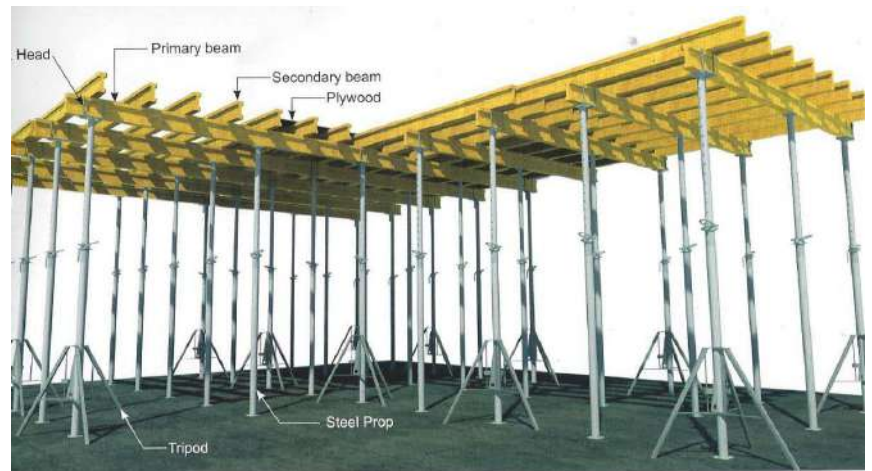

ASSEMBLING DIAGRAMS FOR H20 BEAMS AND PROPS POSITIONING

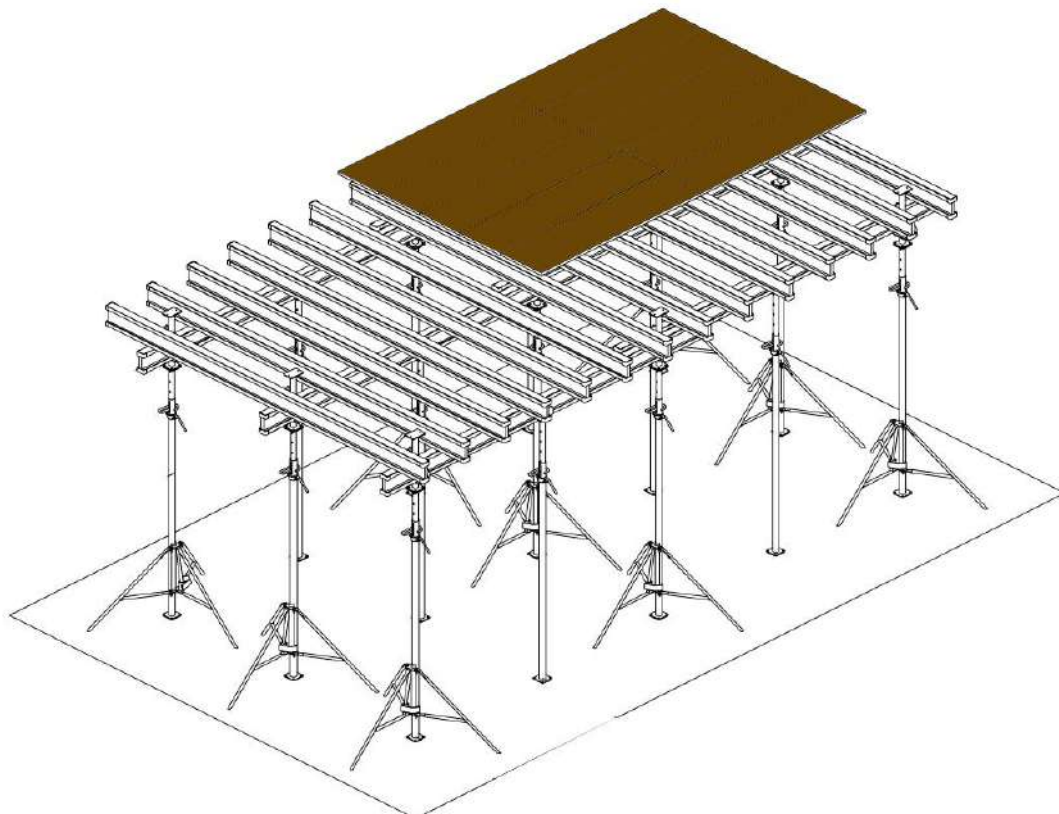

TABLE FORMWORK

Table System is the ideal system for high rise building with open facade.

It is a very simple and effective Formwork system.

The tables are simple unit consisting of a few props, table heads and H20 beams. The H20 Beams can be used as primary and secondary. The Primary H20 beam may be used as single and double. The Table Head has the mechanism to allow the prop to be folded up.



WALL FORMWORK SHUTTERING

ADJUSTABLE VERTICAL WALL SHUTTERING



ADJUSTABLE VERTICAL WALL SHUTTERING

Soldiers are an economic and effective answer to crane handled formwork requirements. They can be used with a wide range of forming systems as timber, aluminum and steel. Soldier has wide range of accessories which allows the soldiers to be used for single or double faced formwork applications.

Advantages

- Easy to handle.
- Ideal for restricted spaces.
- Open web allows ties to be placed at any height
- Wide range of accessories.
- Less demand for maintenance.

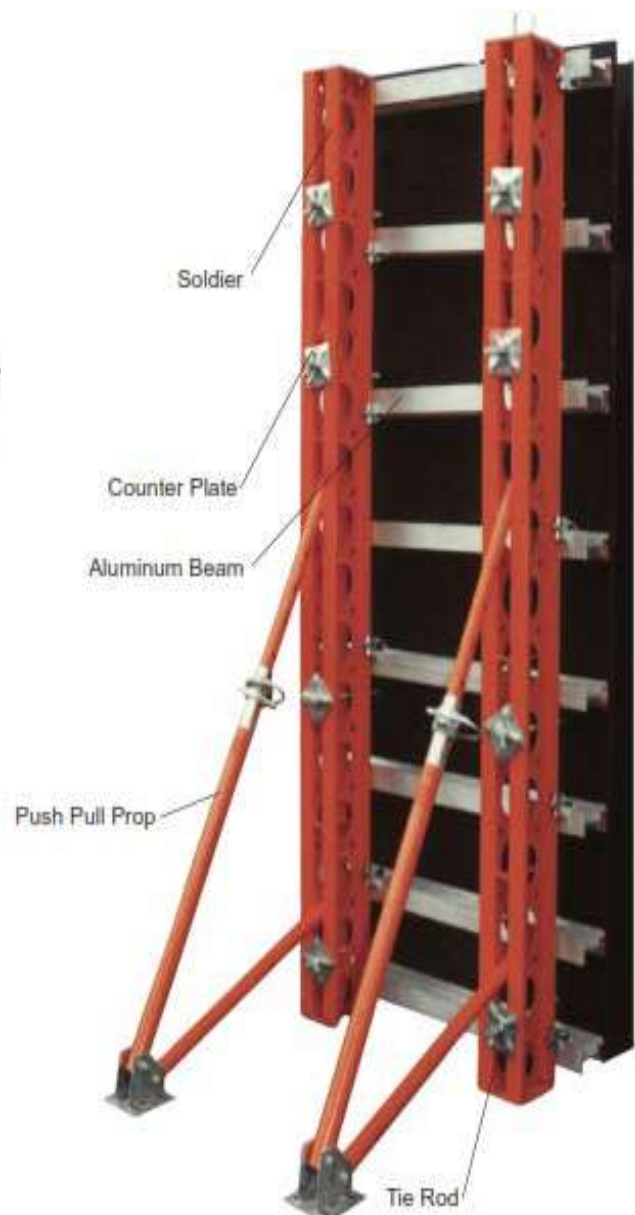

DOUBLE SIDED WALL SHUTTERING

Main Components

- Soldier
- Aluminum Beam
- Double Push Pull Prop
- Wing Nut
- Counter Plate
- Tie Rode
- Universal Clamp
- Accesses bracket

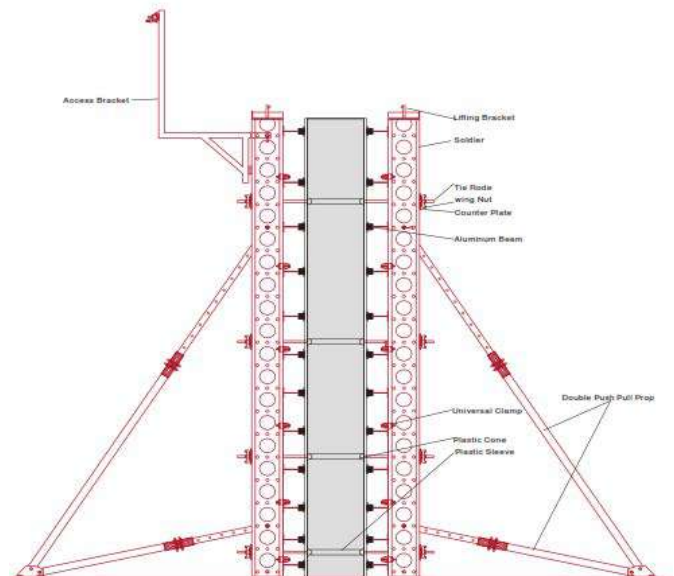

The double sided system of steel formwork gives maximum economy with excellent concrete finish and is used for construction of walls, columns, beams, floors, culverts, docks and precise units. The unique Wall form system of steel shuttering comprise of Standard panels. Channel or Heavy duty soldiers, Tubes or Channel walers. All these components are assembled together by tie rods and special clamps and supported by adjustable push pull props to suit the different height of the shuttering

SINGLE SIDED WALL SHUTTERING

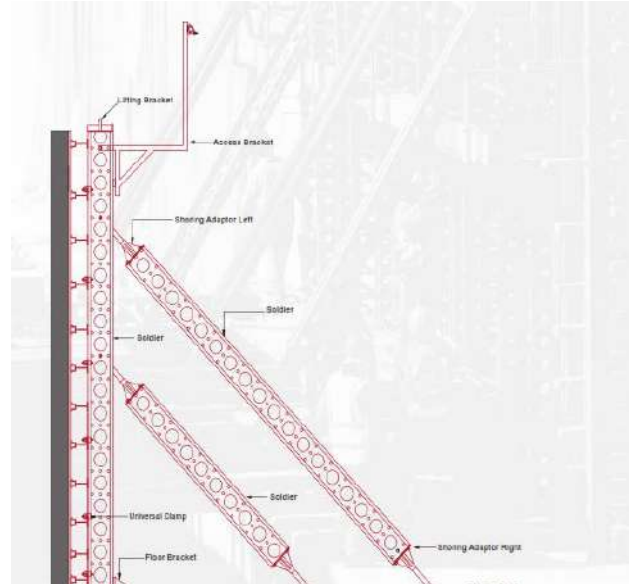

Main Components

- Soldier.
- Aluminum Beam.
- Shoring Adaptor Left.
- Shoring Adaptor Right.
- Floor Bracket
- Shoring Adaptor Base.
- Universal Clamp.



One-Sided Wall Formwork

One sided wall formwork is necessary when a fresh concrete wall is to be poured against an existing wall, earth or piling system. Concrete pressures in one-sided walls can be supported by ties anchored to the existing surface or by extremely strong metal bracing anchored to a hardened concrete foundation. In certain space-limited cases, two-sided wall forms can be used, and one side is left in place behind the poured wall. One-sided wall formwork design is limited by the space available for workers and for the crane.

ADJUSTABLE COLUMN FORMWORK

ADJUSTABLE COLUMN SHUTTERING

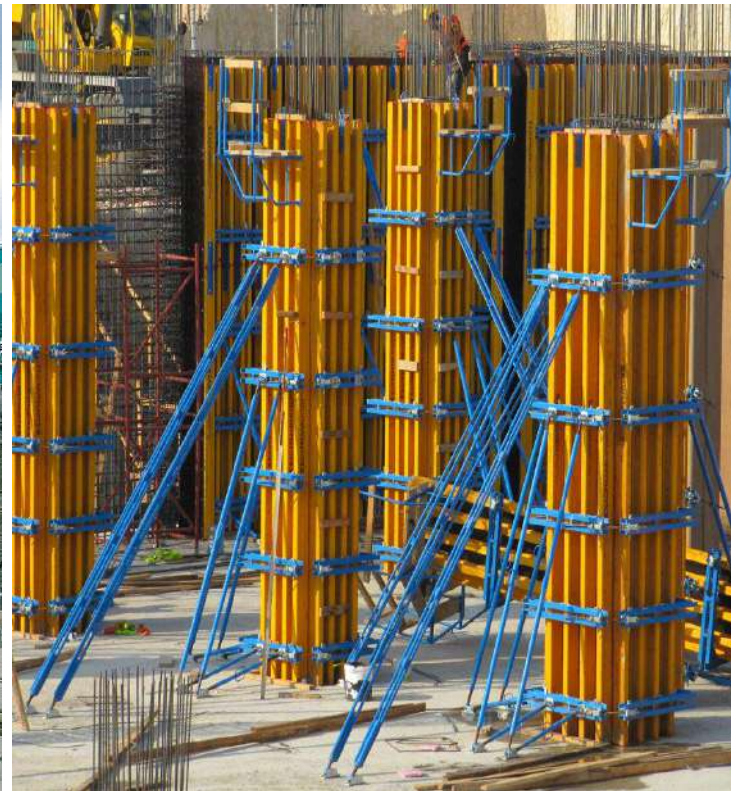

Rectangular adjustable Columns

Adjustable Columns are used to provide the rectangular columns with size adjustment ability . The column size can be adjusted with 5 cm increments in all four sides starting from 25 cm up to 90 cm as well as different panel height . Column shuttering can be either Plywood or steel .

Advantaged of adjustable columns

- 1-Adaptable to various column sizes.
- 2-Speedy erection and dismantling.
- 3-Saves labor costs and time.
- 4-Ensures scarceness and rigidity.
- 5-Excellent surface finish.

Circular Columns



PROPS

- Props are manufactured from high quality material with coated painted finish
- Prop can be used on all types of building construction or for any type of use where an adjustable load bearing member is required.
- The high tensile steel pin is located through a slot in the outer section and a hole on the inner section for coarse adjustment. The cast collar located below the pin gives fine adjustment for leveling or striking.
- The rolled thread ensures no loss of material or strength at this point.
- Weight are given for props having 2mm thick tube.
- Props are available in 2, 3.2 & 4mm thk. Tubes
- Props Can be painted in Different colors



ADJUSTABLE PROPS

- Props with Collar
- Manufactured with high resistance steel tubes STC-37.0.
- Tubes painted with Epoxy Finish and the pin with electroplated finish.
- 3 different sizes with 2 Models covering all loads and measurements.
- Also available in dip painted finish.

- a) Outer Tube
- b) Inner Tube
- c) Collar
- d) Lock Pin
- e) Cap to Cover Collar
- f) Outer Plate 120 x 120 x 4.8 mm
- g) Inner Plate 120 x 120 x 4.8 mm

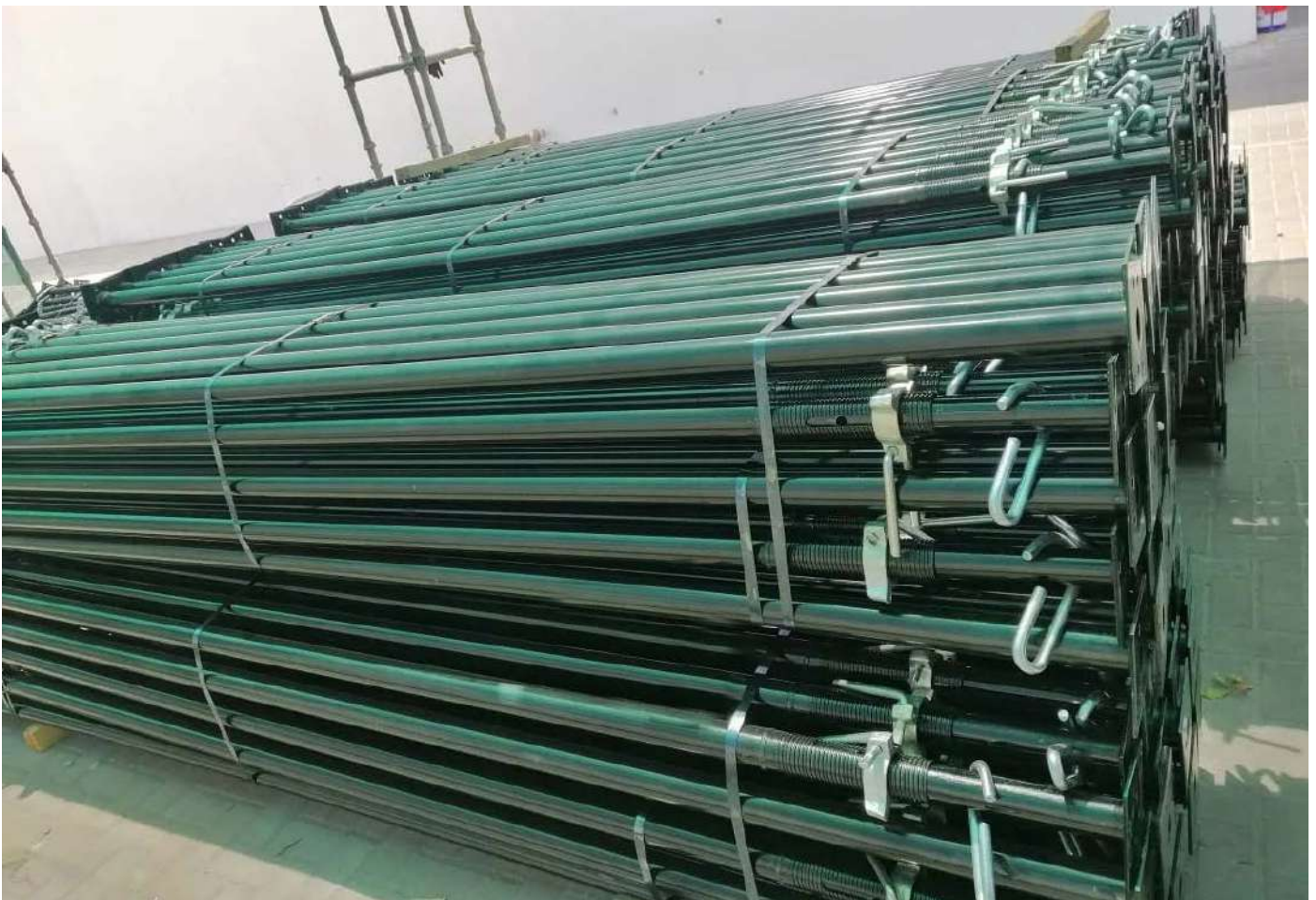
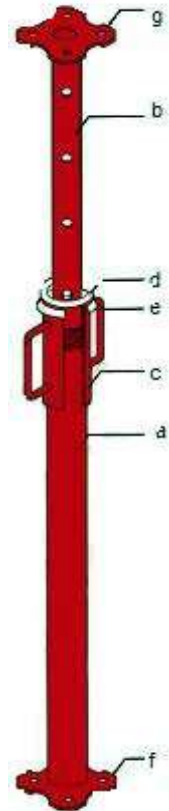

CLIMBING AND SPECIAL FORMWORK SYSTEMS



Climbing formwork (crane-climbing) - in this type of climbing formwork, the formwork around the structure is displaced upwards with the help of one or more Cranes once the hardening of the concrete has proceeded far enough. This may entail lifting the whole section, or be achieved segmentally.

Climbing formwork (self-climbing) - In this type of formwork, the structure elevates itself with the help of mechanic leverage equipment (usually Hydraulic). To do this, it is usually fixed to sacrificial cones or rails emplaced in the [previously cast concrete.]

FORMWORK ACCESSORIES



PLYWOOD H 20



SCAFFOLD WOOD & STEEL PLANKES



SAFETY BARRIERS

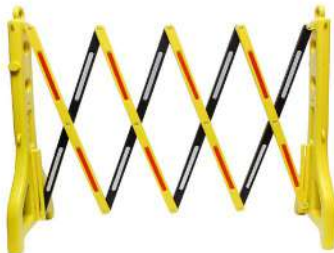

FAÇADE ACCESS SOLUTIONS

Uses

These systems are used in buildings so that people can safely access the external or internal façade for cleaning or maintenance purposes.

These systems are divided into two main types:

1- Permanent systems that are installed on the roof of the permanent systems (such as BMU Machines) or on the counter (such as Monorail system). Or, both together, like Socket & Davit Systems These systems are used in the following works:

Cleaning the external or internal facades of the glass buildings the façade Light maintenance works for facades, such as:

- Install the building's external lights
- Replace the broken glass sheets, bearing in mind that in this case the machine should be designed in advance
- Adornment and external advertisements

Noting that fixed systems are not designed for the purposes of transporting people or materials except in emergencies and in the presence of Persons with patience and jurisdiction to observe.

2- Temporary Systems that are used in construction sites for use in the installation of aluminium, glass, marble and other materials and are removed at the end of the work

Design Criteria

Special criteria to consider when designing:

1. European standards EN1808 are used in the design of these systems
2. The maximum wind speed for using the machine is from 29-38 km / h
3. The bearing strength of the roof Slab for the proposed machine weight
4. There are no concrete or mechanical obstacles on the surface that hinder the movement of the machine
5. Height of the Parapet
6. The height of the building
7. Architectural design of the external facades in terms of the presence of internal bounces in the facades or Internal and external curves
8. The presence of external obstacles on the facades
9. The length of the arm of the machine to reach the farthest point (accordingly it determines the type of rail that is used to walk the machine)



Production Areas

- **Building Maintenance Units**
- **Building Maintenance Units**
- **Facade Cleaning Machines**
- **Electrical Suspended Scaffolding**
- **Special Design/ Custom Made**
- **Rebar Cutting Machines**
- **Rebar Bending Machines**
- **Resistance Bending Machine**

A- Systems

- 1- **Copact machine running on concrete runway (on guide angle)**
- 2- **Fixed telescopic machine on the upper roof**
- 3- **Telescopic machine running on twin track**
- 4- **Telescopic machine with fixed mast**
- 5- **Telescopic machine with telescopic mast**
- 6- **Twin jip arm machine**
- 7- **Monorail system**
- 8- **Gantry system (fixed and telescopic)**
- 9- **Sockets and davits (low and high rise davits)**

B- Cradles:

- 1- **Standard cradle length of 2.4 m**
- 2- **Fixed pantographic cradle**
- 3- **Adjustable pantographic cradle**
- 4- **Powered cradle**
- 5- **One man cradle**
- 6- **Extended cradle**

C- Tracks :

- 1- **Guide angle for compact machines (single track) on the slab**
- 2- **Hot dipped galvanized twin track on top of concrete pedestals on the slab**
- 3- **Elevated twin track on concrete pedestals or steel structure on the slab**
- 4- **Tracks fixed on the parapet**
- 5- **Brackets for the monorail system**



Haigh Rise Davit



Parapet Mounted Low Rise Davit



Roof Machine on Guide angle



Climbing Monorail System



Roof Machine on Guide angle





Roof machine with Pantographic Cradle



Roof machine with Standard Cradle



Special design Machines



Parapet mounted Machine



Telescopic Jib Machine



Telescopic Jib with Telescopic Cradle



Telescopic Jib with Telescopic Mast

FAÇADE CLEANING SOLUTIONS



Telescopic Machine



Pantographic Cradle



High Rise Davits



Powered Cradle

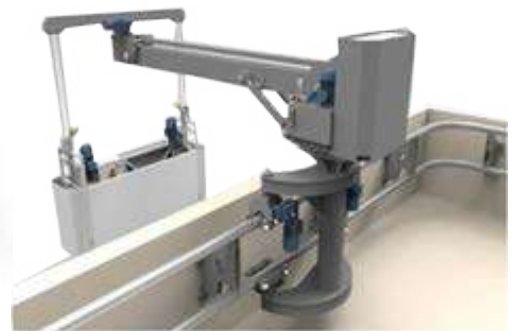

Parapet Mounted Machine



Monorail System



Low Rise Davits



Standard Cradle

SKYLIGHT

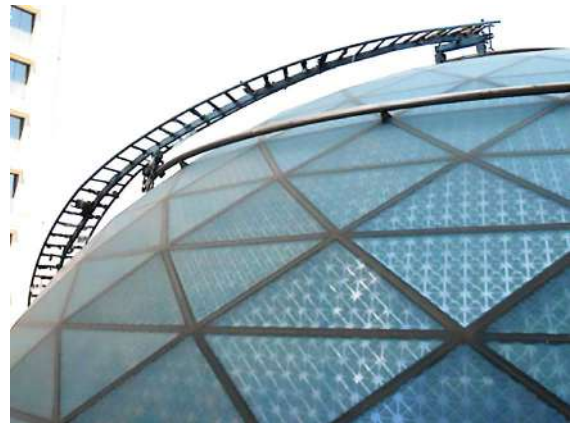
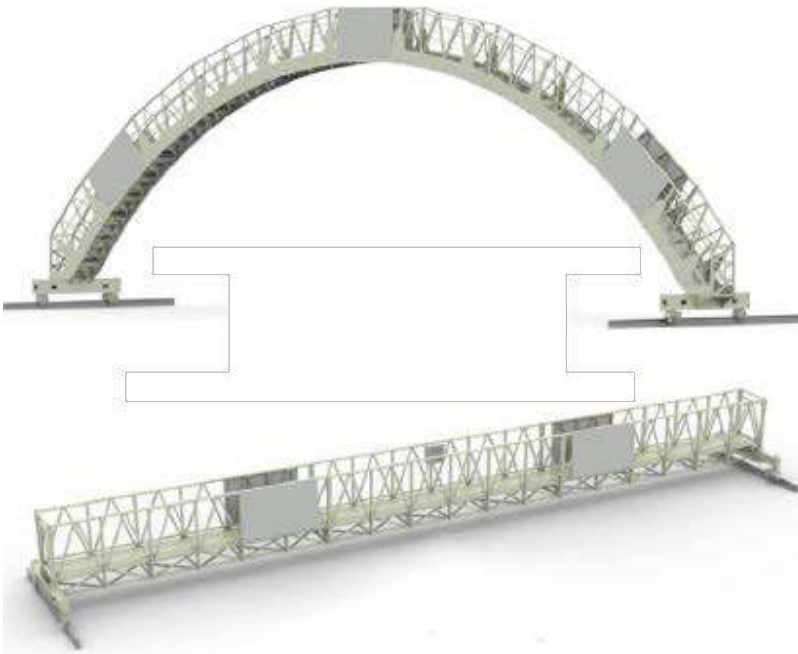

- Is a system to reach the glass skylight area shown on the project.
- Platforms' carrier rails will be anchored via special made brackets to vaults' steel haunch or to the concrete with 2 m distance apart.
- Carriers are hot dipped galvanized.
- Rails will be delivered and designed according to the project and within the standards.
- Carriers and rails' loads will be calculated by the manufacturer and released to contractor
- Platform is to perform its horizontal sliding movement on the 2 pieced rails via the means of electricity.
- Platform capacity will be 240 Kg.
- Platform will be manufactured from aluminium material.
- Vault will be parked at its suitable position.
- Entry and exit to the platform will be performed at its park position.
- Required electricity for the platforms' operation will be supplied by the contractor.
- In order to ensure safety of the operators , in each platform a safety hook and warning signs are placed.
- Optionally safety belts, that are not disassembled and can glide on the guard rails, can be provided o



CRADLE TYPES



Standard 2 Man Powered Cradle



Openable 2 Man Powered Cradle



TEMPORARY CRADLES & MAST CLIMBER



FALL ARREST SYSTEMS



RESTRAINT SOCKETS

- On buildings where the total descent is 40 M or more in height, restraint systems are used for safety and security of the platform.
- In accordance with the building height, first band of restraint sockets are applied on the first 40 M then each and every 20 M.
- As per request the quantity and the ranges could be incremented.
- Horizontal spacing depends on the width of the platform ; application approximately is performed every 2 Mt.
- Connecting point of the sockets and their ranges are calculated in detail by our project engineers.
- Sockets can be connected upon profiles or upon carrier elements.
- Sockets can be produced by either stainless steel or HDG steel.

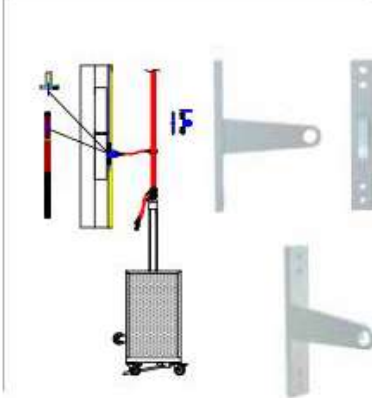
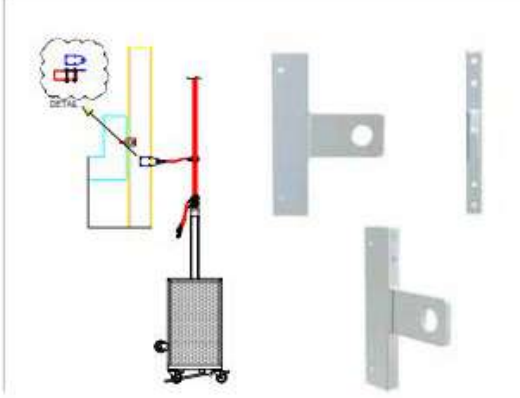
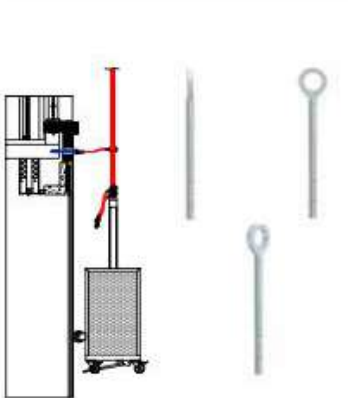
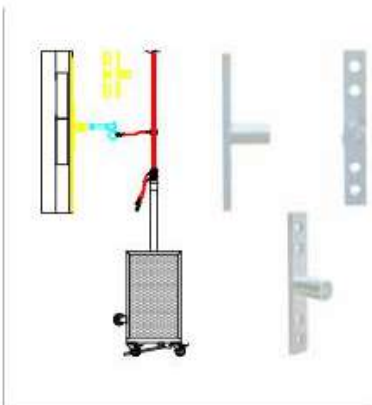
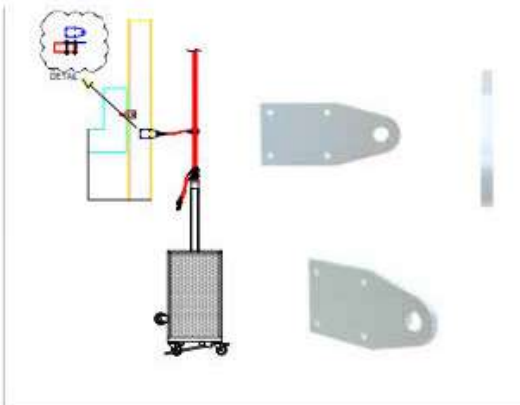
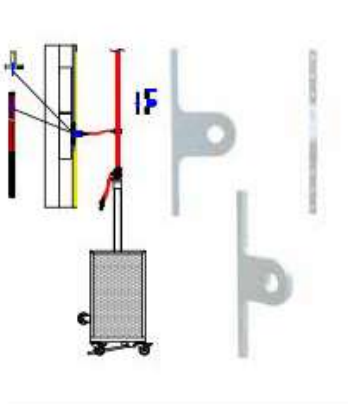

TUCKER POLE



FAÇADE INSTALLATION SYSTEMS

Lifting Winches up to 2000 kg

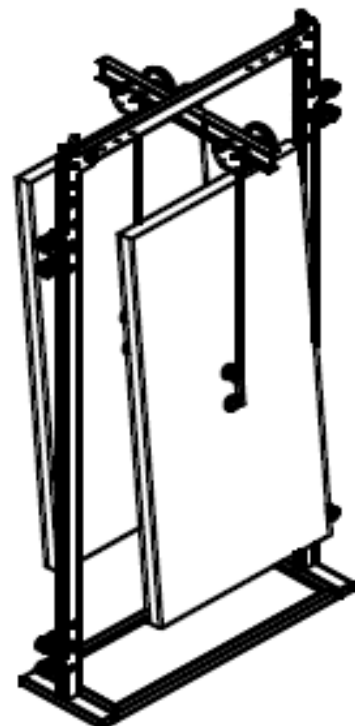

ACCESS EQUIPMENT SOLUTIONS

ACCESS EQUIPMENT SOLUTIONS



Aluminium Tower



Aluminium Tower



Aluminium Platform



Mobile Aluminium Ladder



Aluminium Ladder



ACCESS EQUIPMENT



DOCK LEVELERS & LIFTING TABLE PLATFORMS

Dock Leveller



Lifting Table



ROLLER SHUTTER DOORS



GARBAGE CHUTES AND WASTE MANAGEMENT SYSTEMS

GARBAGE CHUTES AND WASTE SYSTEMS

Garbage Chute

More and more buildings are being built as high-rise units to save space in the city midst's. To dispose of waste and garbage in an easy and effective way these building requires chutes running all the way through the building thereby making it easy for the tenants to dispose of their waste and garbage. We are specializes in the supply and installing these chutes suitable for Hi-rise buildings. These chutes are made up of stainless steel sheets with each floor having an intake door with cleaning and fire fighting sprinklers. Exhaust is provided on the roof top inside the top most section of chute for flushing out the foul smell whatever generated inside the garbage chute..

Garbage Chute

Garbage chute provides an easy and convenient method of garbage collection in multi-storied buildings. Garbage chute is the best way to consolidate garbage from around the building into a single location for easier collection. Manufactured from Stainless steel grade 304 sheets and chute thickness varies from 1.5 mm to 3mm. Chutes are available with a diameter of 500mm, 600mm, 700mm, 800mm and 900mm. We will also manufacture to customer's special requirements

Linen Chute

Linen chute are installed in multi-storied hospitals and hotels for vertical movement of soiled linen/laundry. Our chutes meet most stringent requirement of environment, health and safe

Chute with Bi-Sorter System

- Press the recyclable push button to throw the recyclable wastes
- Then the corresponding signal is passing to the main control panel which gives the information to actuator. The actuator starts functioning and it actuates the movable Separator door to open the recyclable delivery port. Same time the non-recyclable port will be closed completely. This will take 3 seconds to move Separator Door 600 mm radial distance (from recyclable to non-recyclable port).
- Open the hopper door only when the push button lights ON. And throw the garbage which will be collected in Recyclable Trolley placed under the Bi- Sorter Unit. At the same time all other hopper doors will be locked automatically.
- Same procedure is for Non- Recyclable wastes.

GARBAGE CHUTES AND WASTE SYSTEMS



GARBAGE CHUTES COMPONENTS



Bottom Hinged Fire Rated Door



Access Door



Intake Thought With Door



Bi Sorter



GI Garbage Trolley



Fire Sprinkler



Compactor



Fire Shutter door

TEMPORARY GARBAGE CHUTES SYSTEM & SKIP WASTE CONTAINERS



**PORTA CABINS CAMPS , OFFICES AND PREFABRICATED
HOUSES AND BUILDINGS**

**PORTA CABINS CAMPS , OFFICES AND PREFABRICATED
HOUSES AND BUILDINGS**



Multi Story Buildings



Residential Camps



Events And Tournament camps

PORTA CABINS CAMPS , OFFICES AND PREFABRICATED HOUSES AND BUILDINGS



Offices



Schools



Pre Fabricated Offices



Pre Fabricated Offices



Hospitals



**Guard Cabins
Bullet Proof**



PORTA CABINS KIOSKS



BAR BENDING AND CUTTING MACHINES



GRP / CTP MODULAR WATER TANK



CABLE TRAY MANAGEMENT SYSTEM

Metal forming cable trays and accessories are manufactured in compliance with BS 5750/BSEN10130/BSEN10131/BSEN10051 and other international standards

A wide, precise range of products capable of providing the characteristics which respond to the proposed application, along with quality of assembly, speed of installation, and cost saving cable trays

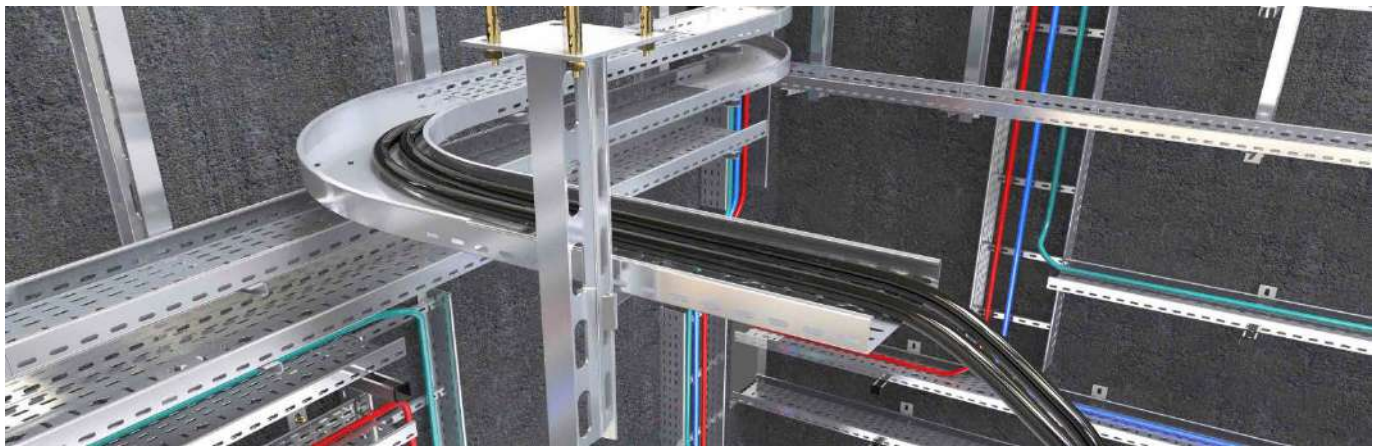

MANHOLE COVERS

Cast iron manhole cover is a high-strength cover plate cast from ductile iron, used in roads and other places. A product that is very common in daily life, on the highway, on the sidewalk, at the pier, in the industrial area, at residence building and commercial buildings you will often see them.

Manhole covers not only are sewers, they can also be used in municipal water supply, gas, electricity, communications and other industries.

Most manhole covers on the market are made of ductile iron, which is a very strong material with strength close to carbon steel, but the price is cheaper than carbon steel.

Classes for Manhole Covers :



Class A 15 Load Resistance 1.5 tons Areas only open for pedestrians and cyclers



Class B 125 Load Resistance 12.5 tons (MD) Pedestrian roads, sidewalks, and areas for loaded vehicles



Class C 250 Load Resistance 25 tons Next to sidewalk, starting from border line maximum 0,5 meters until the road pavement; bordure lines maximum 0,2 meters before pedestrian road



Class D 400 Load Resistance 40 tons (HD) Road pavements (including pedestrian streets), hard banquets and parking areas for all land vehicles



Class E 600 Load Resistance 60 tons Close to common folk, traffic areas that faces heavy loaded vehicles



Class F 900 Load Resistance 90 tons Areas specifically subject to high wheel loads

DUCTILE & CAST MANHOLE GOVERS



ALUMINIUM MANHOLE COVERS

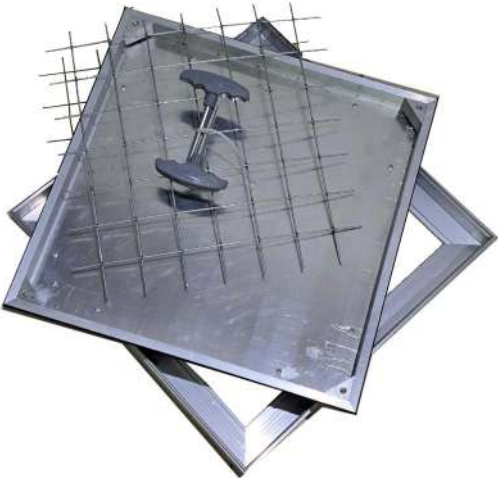

HITECH METAL FORMING

The Edge Of Innovation

HITECH METAL FORMING

Ajman - United Arab Emirate

Emirates Office :

 Tel. 00971-5693 59 799

Qatar Office

 Tel.: 00974 - 66863386

 Tel.: 00974 - 50403055

Jordan Office

 Tel. : 00962 - 795556542

 Emails :info@hitechmf.com , sales@hitechmf.com , farook@hitechmf.com

 www.hitechmf.com