

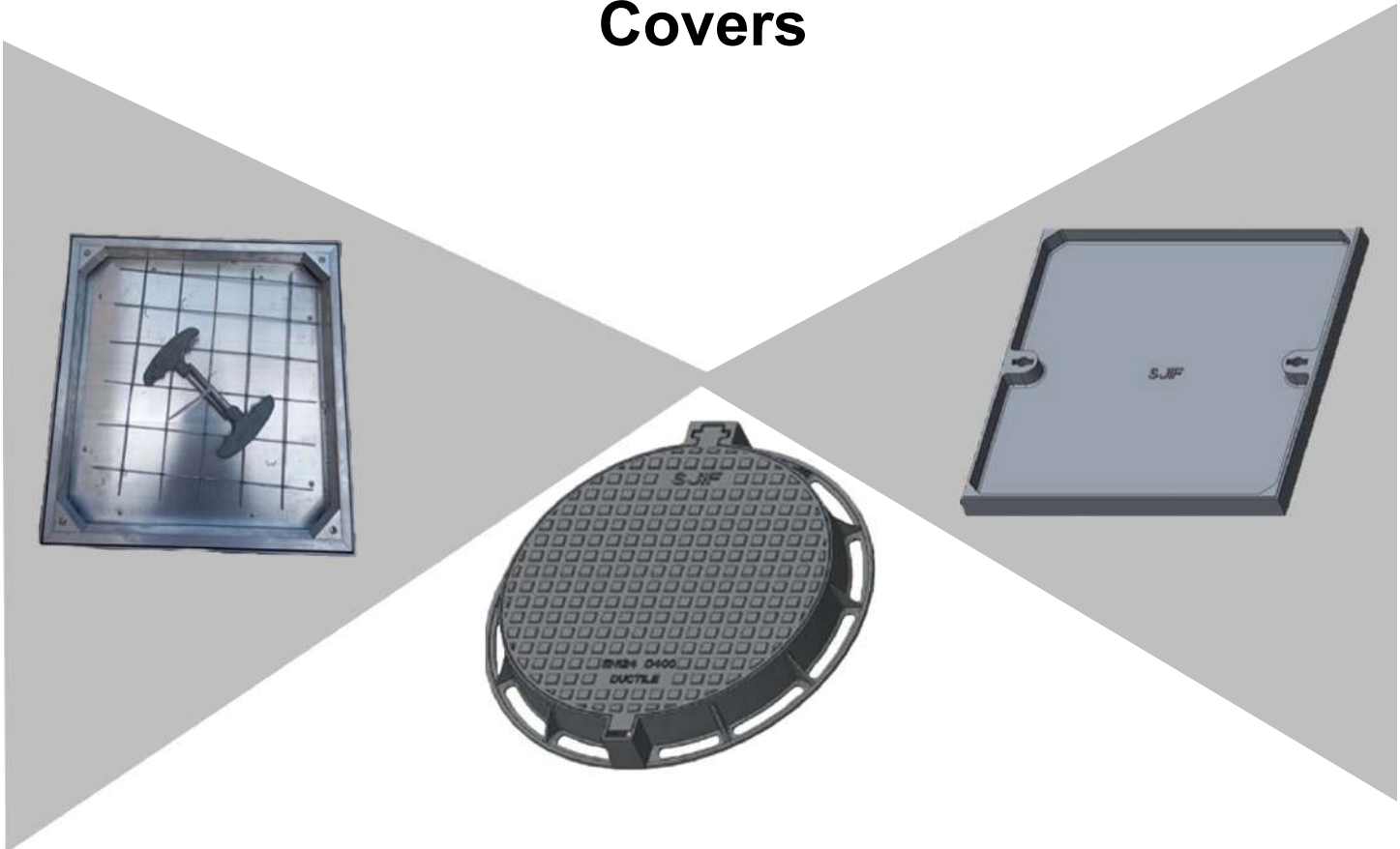

Your Partner For Engineering Services & Solutions

# Ductile & Aluminum Manhole Covers



**COMPANY CATALOGUE 2024 - 2025**

## HITECH COMPANY BRIEF

Hitech Metal Forming is a leading contractor and specialist of Construction material supply manhole covers ( Ductile , Cast and Aluminum )

Our Trading and supply engineering services as a manufacturing representative serve as an orientated and professionally managed company operating in Qatar, GCC and Middle East enter in construction & trading business with quality analytical work force with excellent market and technical knowledge in the line of metal forming of different products as well a material supplier for the construction companies with a vast range of products, having strong knowledge of the Clients & Construction requirements.

Our execution works are carried out by a team of qualified professionals, well trained and certified technicians who can operate the latest high-tech machines. To ensure we remain competitive and up-to-date with technologies, procedures & regulations by offering continuous education and training, considering the safety rules for our manpower by providing required training and workshops. Hitech Metal believes that every project deserves utmost attention and commitment to provide outstanding services that why we continue to diversify it to other fields.

## Who we are

Hitech Metal Forming and Services is Company with main office in Ajman , UAE, Branches in Jordan and Qatar . Our company is Specialized in offering and its distribution of world class product lines to variety of areas such as distribution and manufacturing of scaffolding materials. Access equipment , utilities and construction Materials .We are engage mainly in the field of Construction. We are operating throughout the Gulf Area and Middle East Specialized supplying projects with engineering products and demands.

Our Hitech Team provides full design and calculation services for any project requirement, to the latest industry codes of practice. “committed to innovation and integrity in design, quality and safety in manufacturing” “dedicated to excellence through quality performance, for the mutual long-term success of our customers and ourselves.”

## Vision

Hitech Metal Forming and Services is dedicated to becoming the industry’s preferred supplier for the of scaffolding materials. We are committed to :

- 1- Innovation and integrity in design.
- 2 - Quality ,and service excellence, time to delivery and competitive project values .

## Mission

Our mission is to be a world-class Supplier of metal fabricated products and services. We believe in the development of highly skilled team members committed to continuous improvement. We stride to:

- 1- Provide all requirements within reasonable time, cost and client satisfaction
- 2 - Continuously improve our performance in the construction site demands
- 3- Follow up all HSE and industry requirements

## Values

We value:

- Our people
- Customer Satisfaction
- Accountability
- Integrity
- Hard Work
- Trust & Loyalty
- Confidence
- Good Management



# DUCTILE & CAST MANHOLE COVERS

Cast iron manhole cover is a high-strength cover plate cast from ductile iron, used in roads and other places. A product That is very common in daily life, on the highway, on the sidewalk, at the pier, in the Industrial area, at residence Building and commercial Buildings you will often See them. Manhole covers Not only are sewers, they can Also be used in municipal .Water supply, gas, electricity, communications and other industries. Most manhole covers on the market are made of ductile iron, which is a very strong material with strength close to carbon steel, but the price is cheaper than carbon steel.

Ductile iron manhole covers are designed to provide access to underground utility systems such as sewers, storm drains, and telecommunications. These covers are made from ductile iron, a type of cast iron that is known for its high strength, durability, and ability to withstand heavy loads.

#### **Ductile Iron Manhole Covers**

Ductile Iron Manhole Covers are manufactured In a wide range .These covers are made as per BS EN 124 & can have testing load capacities of 1.5 MT, 12.5 MT, 25 MT to up to 40 MT. Upon request, they are also manufactured with load capacities of up to 90 MT which are used at Airports.

A wide range variety can be manufactured like Recessed Covers, Single Seal Solid Top, Double Seal & hinged type covers. These products are available in both round & square frames. The sizes are 200mm dia round , 200mm x 200mm square to up to 1500mm dia / 1500mm x 1500mm square type covers.





## WHAT IS CAST IRON

Cast irons, like steels, are basically alloys of iron and carbon. In relation to the iron-iron carbide diagram, cast irons contain a greater amount of carbon than that necessary to saturate austenite at the eutectic temperature. Therefore, cast irons contain between 2 and 6.67 per cent carbon. Since high carbon content tends to make the cast iron very brittle, most commercially manufactured types have in the range of 2.5 to 4 per cent carbon.

Cast Iron melts readily and can be cast into complicated shapes which are usually machined to final dimensions. Since casting is the only suitable process applied to these alloys, they are known as cast irons.

## STANDARD CLASSIFICATION

The appropriate class of manhole cover to be used depends upon the place of installation. The various places of installation have been divided into groups numbered 1 to 6, listed below. A guide as to which class of manhole cover should be used is shown in parentheses for each group. The selection of the appropriate class is the responsibility of the designer. Where there is any doubt, the stronger class should be selected.

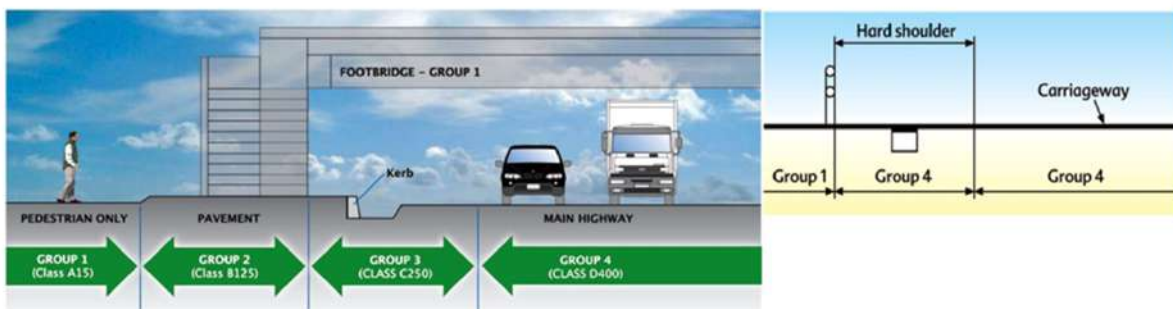

**Group 1 (Class A15)** : Areas which can only be used by pedestrians and pedal cyclists.



**Group 2 (Class B125)** : Footways, pedestrian areas and comparable areas, car parks or car parking decks.



**Group 3 (Class C 250)** : For gully tops installed in the area of kerbside channels of roads which when measured from the kerb edge, extend a maximum of 0.5 m into the carriageway and a maximum of 0.2 m into the footway.



**Group 4 (Class D 400)** : Carriageways of roads (including pedestrian streets), hard shoulders and parking areas, for all types of road vehicles.



**Group 5 (Class E 600)** : Areas imposing high wheel loads, e.g. docks, aircraft pavements.



**Group 6 (Class F 900)** : Areas imposing particularly high wheel loads, e.g aircraft pavements.



# PRODUCT RANGE

"JIF" BRAND RECTANGULAR ISI MARKED CAST IRON COVERS & FRAME

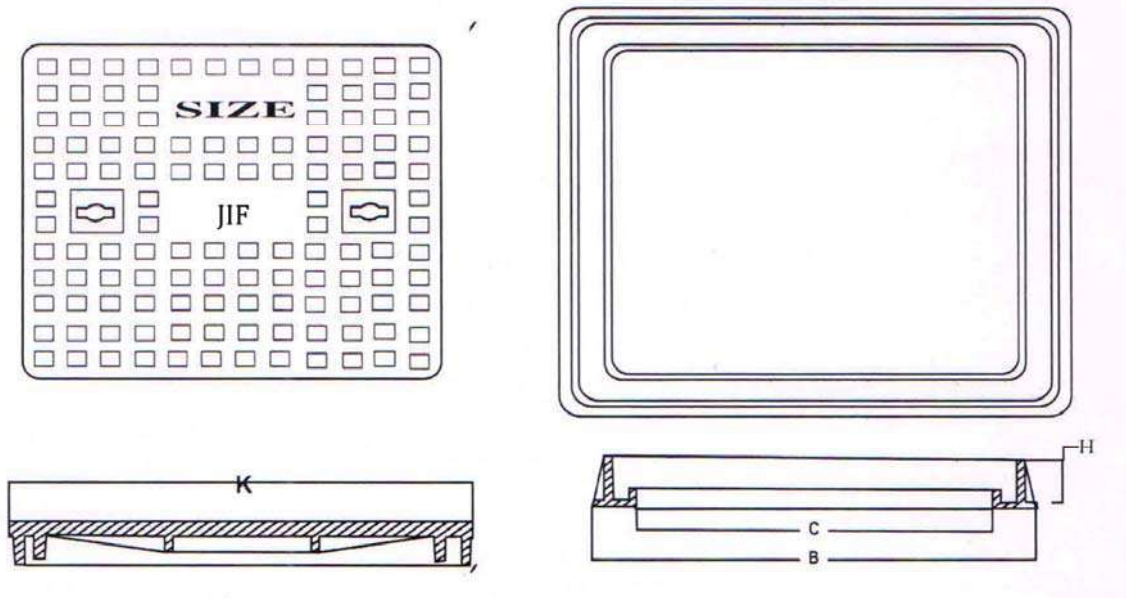

SIZE DIA	CLEAR OPENING ©	COVER OUTER (K)	OUTER BASE (FRAME) (B)	DEPTH (H)	LOAD TESTED
300 X 300 X 17 KGS.	300	405	440	33	5 TON
450 X 450 X 32 KGS.	453	560	595	30	
450 X 450 X 45 KGS.	443	583	612	38	2.5 TON
600 X 600 X 65 KGS.	596	704	740	40	
600 X 600 X 115 KGS.	600	730	804	75	10 TON
560 X 560 X 250 KGS.	560	720	838	122	25 TON

TOLLERANCE IN SIZE +/- 5MM IN THICKNESS +/- 1MM & IN WT +/- 5%  
(ALL DIMENSION IN MM)



"JIF" BRAND RECTANGULAR ISI MARKED CAST IRON COVERS & FRAME

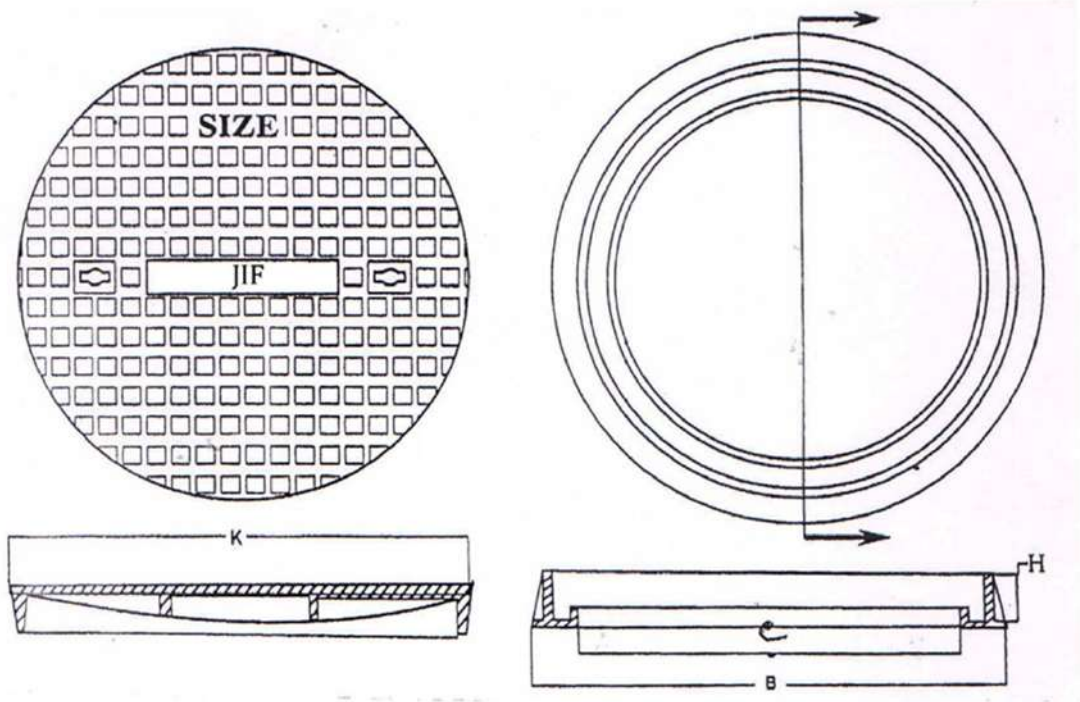

SIZE DIA	CLEAR OPENING ©	COVER OUTER (K)	OUTER BASE (FRAME) (B)	DEPTH (H)	LOAD TESTED
18" X 52 KGS.	450	625	704	55	8 TON
18" X 65 KGS.	450	625	704	55	10 TON
22" X 80 KGS.	500	665	746	75	10 TON
TOLLERANCE IN SIZE +/- 5MM IN THICKNESS +/- 1MM & IN WT +/- 5% (ALL DIMENSION IN MM)					

"JIF" BRAND RECTANGULAR ISI MARKED CAST IRON COVERS & FRAME

EARTH PIT COVER  
(HINGE COVER)

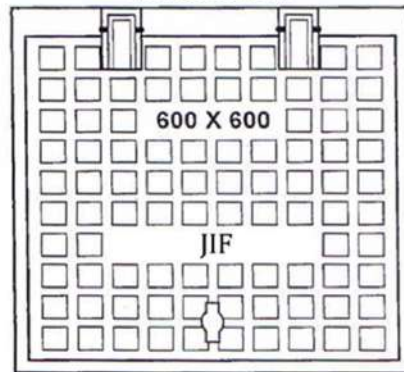

(ALL DIMENSION IN MM)

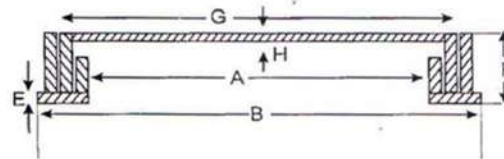

Sl. No.	FRAME					COVER		WEIGHT		TOTAL
	C.O A	O.D B	I.D B	THICKNESS E	HEIGHT F	O.D G	THICKNESS	COVER	FRAME	WT
	600 X 600	700 X 700	650 X 650		40	640 X 640				40 KGS
TOLLERANCE IN SIZE +/- 5MM IN THICKNESS +/- 1MM & IN WT +/- 5% (ALL DIMENSION IN MM)										

## ROUND ACCESS COVERS

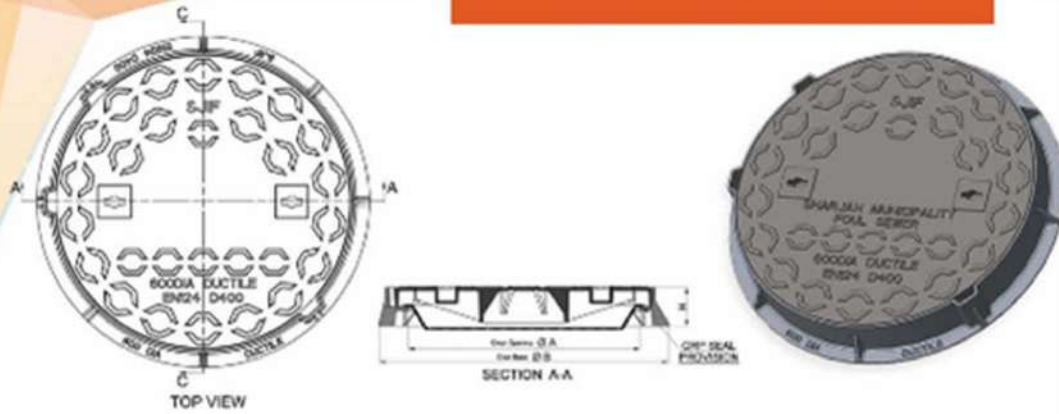

Clear Opening(mm)	Over Base(mm)	Load	Height(mm)
600	750	D400	100
600	800	D400	100

\* Patterns above are indicative. Various other sizes are available.

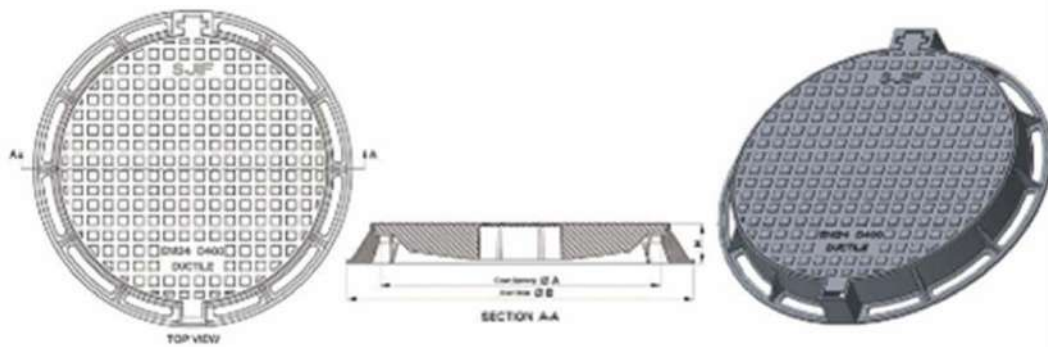

Clear Opening(mm)	Over Base(mm)	Load	Height(mm)
675	835	D400	100
600	750	D400	100

\* Patterns above are indicative. Various other sizes are available.

## SQUARE ACCESS COVERS

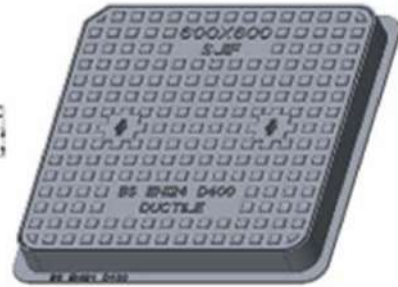
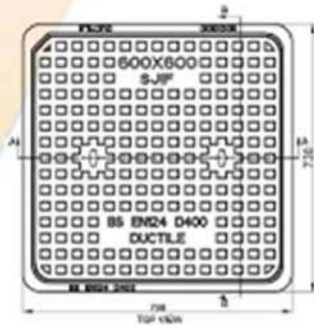

Clear Opening(mm)	Over Base(mm)	Load	Height(mm)	No. of Seal
600 x 600	730 x 730	D400	75	Single Seal
800 x 800	960 x 960	D400	100	Single Seal
700 x 700	850 x 850	D400	100	Single Seal
400 x 400	490 x 490	D400	50	Single Seal
500 x 500	590 x 590	D400	50	Single Seal
300 x 300	400 x 400	B125	40	Single Seal
300 x 300	420 x 420	D400	75	Single Seal
450 x 450	550 x 550	B125	40	Single Seal
450 x 450	570 x 570	D400	75	Single Seal
750 x 750	930 x 930	D400	100	Single Seal

\* Patterns above are indicative. Various other sizes are available.



Clear Opening(mm)	Over Base(mm)	Load	Height(mm)
600 x 600	720 x 720	D400	100
750 x 750	900 x 900	D400	100
1000 x 1000	1160 x 1160	D400	100

\* Patterns above are indicative. Various other sizes are available.



## SQUARE ACCESS COVERS

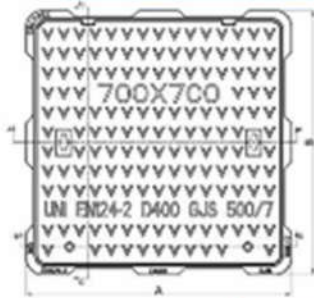

Clear Opening(mm)	Over Base(mm)	Load	Height(mm)
202 x 202	300 x 300	B125	30
302 x 302	400 x 400	B125	30
400 x 400	500 x 500	B125	30
500 x 500	600 x 600	B125	35
600 x 600	700 x 700	B125	40
400 x 400	500 x 500	D400	40
400 x 400	500 x 500	D400	75
500 x 500	600 x 600	D400	75
600 x 600	700 x 700	D400	75

\* Patterns above are indicative. Various other sizes are available.

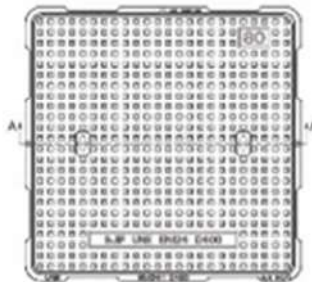

Clear Opening(mm)	Over Base(mm)	Load	Height(mm)
400 x 400	500 x 500	D400	75
500 x 500	600 x 600	D400	75
600 x 600	700 x 700	D400	75
700 x 700	820 x 820	D400	100
800 x 800	920 x 920	D400	100

\* Patterns above are indicative. Various other sizes are available.



## RECESSED COVERS



Clear Opening(mm)	Over Base(mm)	Load	Height(mm)	No. of Seal
600 x 600	730 x 730	D400	75	Single Seal
800 x 800	960 x 960	D400	100	Single Seal
700 x 700	850 x 850	D400	100	Single Seal
400 x 400	490 x 490	D400	50	Single Seal
500 x 500	590 x 590	D400	50	Single Seal
300 x 300	400 x 400	B125	40	Single Seal
300 x 300	420 x 420	D400	75	Single Seal
300 x 300	480 x 480	D400	100	Single Seal
450 x 450	600 x 600	D400	100	Single Seal
600 x 600	750 x 750	D400	90	Single Seal
800 x 800	960 x 960	D400	100	Single Seal
900 x 900	1080 x 1080	D400	100	Single Seal
1000 x 1000	1180 x 1180	D400	100	Single Seal

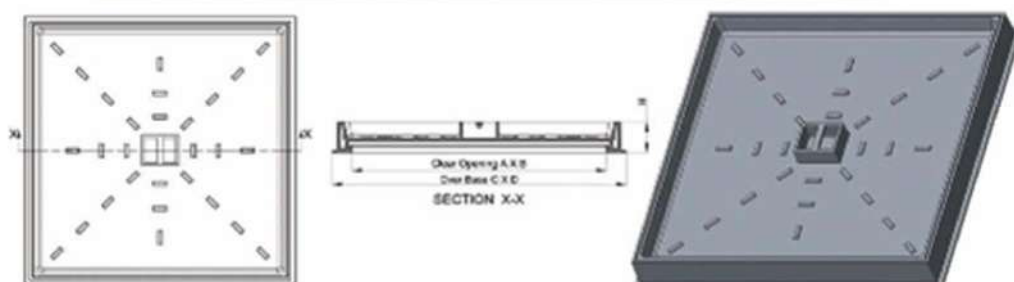

Clear Opening(mm)	Over Base(mm)	Load	Height(mm)
408 x 408	720 x 720	B125/C250/D400	57.5
522 x 522	900 x 900	B125/C250/D400	63

\* Patterns above are indicative. Various other sizes are available.

## GULLY GRATES

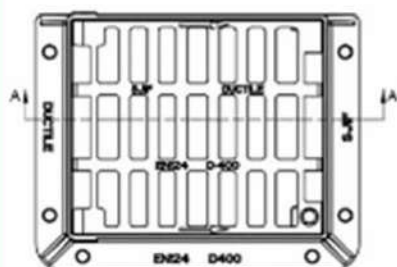
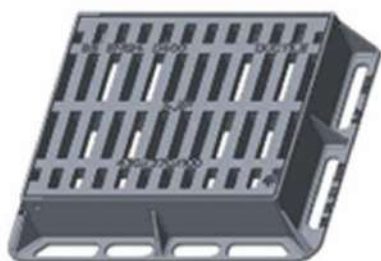

TOP VIEW

Clear Opening(mm)	Over Base(mm)	Load	Total Depth
300 x 300	333 x 350	125kN	50
450 x 450	540 x 664	180kN	87
280 x 360	440 x 360	C250	70
300 x 300	400 x 400	D400	75
600 x 600	700 x 700	D400	100
430 x 370	540 x 441	D400	100
385 x 315	530 x 403	D400	100
336 x 308	496 x 398	D400	75
400 x 400	500 x 500	D400	100
450 x 450	538 x 592	D400	100



\* Patterns above are indicative, Various other sizes are available.

## CHANNEL GRATES

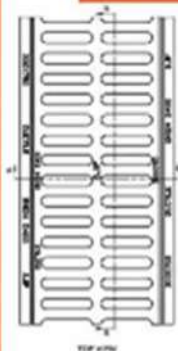

TOP VIEW

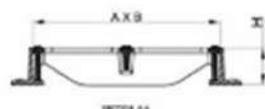

SECTION AA

Clear Opening(mm)	Length (mm)	Load	Seating Depth
150	750	C250	25
250	700	C250	25
450	750	D400	25
350	750	D400	25
300	750	D400	25
250	750	D400	25
200	750	D400	25
250	700	D400	25
400	750	D400	35
100	750	D400	25
600	750	D400	25
450	750	D400	35
450	750	F900	50
400	750	F900	50
300	750	F900	50
80	600	.....	60

\* Patterns above are indicative. Various other sizes are available.

## CARRIAGEWAYS

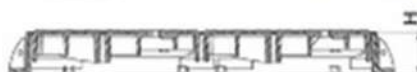
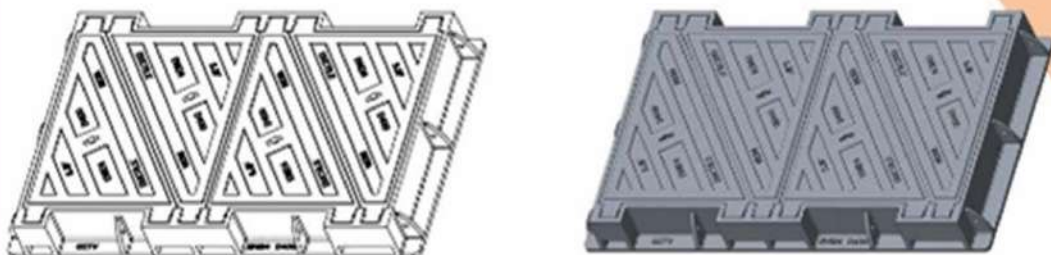

Clear Opening(mm)	Over Base(mm)	Load	Height(mm)
702 x 702	910 x 910	D400	100
702 x 1402	910 x 1610	D400	100
696 x 696	1374 x 850	D400	150
696 x 1830	850 x 1984	D400	150

\* Patterns above are indicative. Various other sizes are available.

## CARRIAGEWAY / MANHOLE COVER ACCESSORIES :



Bracket Cable Bearer



Indented Foundation Bolts



Grating Sump



Cable Bearer



Iron Anchor-4



Pin Locking Cable Bearer

### STEP IRON :

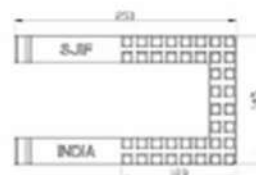

Length	Breadth	Height(mm)
175	145	125
185	145	125
250	145	125
370	145	125
250	150	125

### LIFTING KEY :



Type	Length	Breadth
"T" TYPE	280	130
"V" TYPE	290	150

\* Patterns above are indicative. Various other sizes are available.

# ALUMINUM MANHOLE COVERS



## HEAVY DUTY ALUM. MANHOLE COVERS

Manhole Covers 2 doors					إغطية مناهل باين
Internal Frame Height	Internal Frame	Outer Frame Height	Net Outer Frame	Outer Frame	TYPE
E	D	C	B	A	
4.7 cm	16 cm	6.3 cm	6.5 cm	20 cm	20 x 20 cm
4.7 cm	26 cm	6.3 cm	16.5 cm	30 cm	30 x 30 cm
4.7 cm	36 cm	6.3 cm	26.5 cm	40 cm	40 x 40 cm
4.7 cm	46 cm	6.3 cm	36.5 cm	50 cm	50 x 50 cm
4.7 cm	56 cm	6.3 cm	46.5 cm	60 cm	60 x 60 cm
4.7 cm	66 cm	6.3 cm	56.5 cm	70 cm	70 x 70 cm
4.7 cm	76 cm	6.3 cm	66.5 cm	80 cm	80 x 80 cm
4.7 cm	86 cm	6.3 cm	76.5 cm	90 cm	90 x 90 cm
4.7 cm	96 cm	6.3 cm	86.5 cm	100 cm	100 x 100 cm

Manhole covers 2 doors					إغطية مناهل باين
Internal Frame Height	Internal Frame	Outer Frame Height	Net Outer Frame	Outer Frame	TYPE
E	D	C	B	A	
4.7 cm	24.5 x 56 cm	6.3 cm	25 x 48 cm	60 cm	60 x 60 cm
4.7 cm	29.5 x 66 cm	6.3 cm	30 x 58 cm	70 cm	70 x 70 cm
4.7 cm	34.5 x 76 cm	6.3 cm	35 x 68 cm	80 cm	80 x 80 cm
4.7 cm	39.5 x 86 cm	6.3 cm	40 x 78 cm	90 cm	90 x 90 cm
4.7 cm	44.5 x 96 cm	6.3 cm	45 x 88 cm	100 cm	100 x 100 cm
4.7 cm	49.5 x 106 cm	6.3 cm	50 x 98 cm	110 cm	110 x 110 cm
4.7 cm	54.5 x 116 cm	6.3 cm	55 x 108 cm	120 cm	120 x 120 cm

Manhole covers 3 doors					إغطية مناهل ثلاثة ابواب
Internal Frame Height	Internal Frame	Outer Frame Height	Net Outer Frame	Outer Frame	TYPE
E	D	C	B	A	
4.7 cm	27 x 86 cm	6.3 cm	24 x 78 cm	90 cm	90 x 90 cm
4.7 cm	30.5 x 96 cm	6.3 cm	27 x 88 cm	100 cm	100 x 100 cm
4.7 cm	37 x 116 cm	6.3 cm	54 x 108 cm	120 cm	120 x 120 cm

### المواصفات الفنية:

الزبر :  
الغطاء له زبر مزدوج ومصنوع من  
مادة PDM ومقاوم للظروف الجوية

براغي الزاوية :  
ستانلس ستيل

الشبكة الحديد :  
سماعة 2.3 ملم

البروفيلات:  
مصنوع من مادة الألمونيوم  
النقي من أفضل الشركات

الألواح:  
مصنوعة من انقى انواع  
الالمنيوم، سماكة 2 ملم  
ومغلف من الاسفل بطبقة  
بلاستيك لحمايته من ظروف  
اللكسدة وابخرة المياه

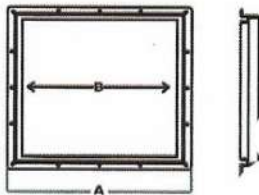
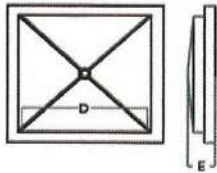

#### Technical Specifications :

**Profile :** Pure Aluminum

**Sheet :** 2 mm thickness wrapped from Below w  
Plastic to protect from oxidation and wat  
vapors

**Rubber :** Double Made from PDM

**Bolts :** Stainless Steel

**Wire Mesh :** 2.3 mm Thickness



## MEDIUM DUTY ALUM. MANHOLE COVERS

MANHOLE COVERS					إغطية مناهل
INTERNAL COVER HEIGHT	INTERNAL COVER	OUTER FRAME HEIGHT	NET OUTER FRAME OPENING	OUTER FRAME	
E	D	C	B	A	
3.5 CM	27 CM	4.7 CM	20.0 CM	30 CM	30×30 CM
3.5 CM	37 CM	4.7 CM	30.0 CM	40 CM	40×40 CM
3.5 CM	47 CM	4.7 CM	40.0 CM	50 CM	50×50 CM
3.5 CM	57 CM	4.7 CM	50.0 CM	60 CM	60×60 CM
3.5 CM	67 CM	4.7 CM	60.0 CM	70 CM	70×70 CM
3.5 CM	77 CM	4.7 CM	70.0 CM	80 CM	80×80 CM

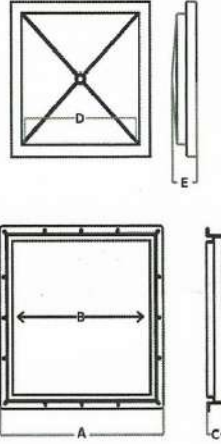

### المواصفات الفنية:

الرببر :  
الغطاء له رببر مزدوج ومصنوع من  
مادة PDM ومقاوم لظروف الجوية

براغي الزاوية :  
ستانلس ستيل

الشبك الحديد :  
سماكة 2.3 ملم

البروفيلات:  
مصنوع من مادة الألمونيوم  
النقي من أفضل الشركات

الألواح:  
مصنوعة من انقى انواع  
الالمنيوم، سماكة 2 ملم  
ومغلف من الاسفل بطبقة  
بلاستيك لحمايته من ظروف  
اللكسدة وابخرة المياه

### Technical Specifications :

**Profile** : Pure Aluminum

**Sheet** : 2 mm thickness wrapped from Below with  
Plastic to protect from oxidation and water  
vapors

**Rubber** : Double Made from PDM

**Bolts** : Stainless Steel

**Wire Mesh** : 2.3 mm Thickness

Silver Square Trading &amp; Invs.

Made In Jordan

مصنع الربيع الفضي

صنع في الأردن

اغطية مناهل

## MANHOLE COVERS

## اغطية مناهل

ارتفاع الغطاء المنحلي	قطر الغطاء	ارتفاع الغطاء المنحلي	قطر فتحة الغطاء المنحلي	الغوص المنحلي	الغوص
E	D	C	B	A	
4.7 cm	16 cm	6.3 cm	6.5 cm	20 cm	20x20 cm
4.7 cm	26 cm	6.3 cm	16.5 cm	30 cm	30x30 cm
4.7 cm	36 cm	6.3 cm	26.5 cm	40 cm	40x40 cm
4.7 cm	46 cm	6.3 cm	36.5 cm	50 cm	50x50 cm
4.7 cm	56 cm	6.3 cm	46.5 cm	60 cm	60x60 cm
4.7 cm	66 cm	6.3 cm	56.5 cm	70 cm	70x70 cm
4.7 cm	76 cm	6.3 cm	66.5 cm	80 cm	80x80 cm
4.7 cm	86 cm	6.3 cm	76.5 cm	90 cm	90x90 cm
4.7 cm	96 cm	6.3 cm	86.5 cm	100 cm	100x100 cm



## اغطية مناهل باين

ارتفاع الغطاء المنحلي	قطر الغطاء	ارتفاع الغطاء المنحلي	قطر فتحة الغطاء المنحلي	الغوص المنحلي	الغوص
E	D	C	B	A	
4.7 cm	24.5 x 56 cm	6.3 cm	25 x 48 cm	60 cm	60 x 60 cm
4.7 cm	29.5 x 66 cm	6.3 cm	30 x 58 cm	70 cm	70 x 70 cm
4.7 cm	34.5 x 76 cm	6.3 cm	35 x 68 cm	80 cm	80 x 80 cm
4.7 cm	39.5 x 86 cm	6.3 cm	40 x 78 cm	90 cm	90 x 90 cm
4.7 cm	44.5 x 96 cm	6.3 cm	45 x 88 cm	100 cm	100 x 100 cm
4.7 cm	49.5 x 106 cm	6.3 cm	50 x 98 cm	110 cm	110 x 110 cm
4.7 cm	54.5 x 116 cm	6.3 cm	55 x 108 cm	120 cm	120 x 120 cm

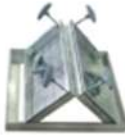

## اغطية مناهل ثلاثة ابواب

ارتفاع الغطاء المنحلي	قطر الغطاء	ارتفاع الغطاء المنحلي	قطر فتحة الغطاء المنحلي	الغوص المنحلي	الغوص
E	D	C	B	A	
4.7 cm	27 x 86 cm	6.3 cm	24 x 78 cm	90 cm	90 x 90 cm
4.7 cm	30.5 x 96 cm	6.3 cm	27 x 88 cm	100 cm	100 x 100 cm
4.7 cm	37 x 116 cm	6.3 cm	34 x 108 cm	120 cm	120 x 120 cm



## المواصفات الفنية:

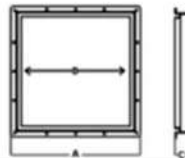
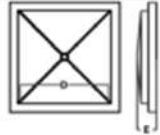

البروفيلات: مصنوع من مادة الالمنيوم النقي من أفضل الشركات.  
الالواح: مصنوعة من النقي انواع الالمنيوم وسماكة 2 ملم ومغلف من الاسفل بطبقة بلاستيك لحمايته من ظروف الاكسدة وابتحة المياه.  
الزبر: الغطاء له زبر مزدوج ومصنوع من مادة PDM ومقاوم للظروف الجوية.

براغي الزاوية ستانلس ستيل.

تم عملية الكيس والتصنيع للزوايا بنظام الكيس عالي الجودة واحداث الماكينات في العالم.

الشبك حديد سماكة 2,3 ملم.

شركة الربيع الفضي للتجارة والاستثمار - ذرية النور - ناوا - شارع دانا 3 - عمان - الأردن - الهاتف: 064120096 - الفاكس: 064120097 - الدواخيل: 0799465339  
alrbaie@outlook.com البريد الإلكتروني: silversquare1@outlook.com

- يتم تفصيل اي مقاس حسب الطلب -

Silver Squire Trading & Inves.  
Made In Jordan

مصنع المربع الفضي

صنع في الأردن  
اغطية مناهل Geint

#### MANHOLE COVERS

#### اغطية مناهل

ارتفاع قطعة الفولاذ	قطعة الفولاذ	ارتفاع الغيوم الخاربي	مقاسي فتحة الغيوم الخاربي	الغيوم الخاربي	الاصف
E	D	C	B	A	
4.7 cm	16 cm	6.3 cm	6.5 cm	20 cm	20x20 cm
4.7 cm	26 cm	6.3 cm	16.5 cm	30 cm	30x30 cm
4.7 cm	36 cm	6.3 cm	26.5 cm	40 cm	40x40 cm
4.7 cm	46 cm	6.3 cm	36.5 cm	50 cm	50x50 cm
4.7 cm	56 cm	6.3 cm	46.5 cm	60 cm	60x60 cm
4.7 cm	66 cm	6.3 cm	56.5 cm	70 cm	70x70 cm
4.7 cm	76 cm	6.3 cm	66.5 cm	80 cm	80x80 cm
4.7 cm	86 cm	6.3 cm	76.5 cm	90 cm	90x90 cm
4.7 cm	96 cm	6.3 cm	86.5 cm	100 cm	100x100 cm

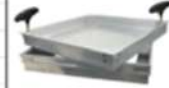

#### اغطية مناهل باين

ارتفاع القطعة الفولاذي	القطعة الفولاذي	ارتفاع الغيوم الخاربي	مقاسي فتحة الغيوم الخاربي	الغيوم الخاربي	الاصف
E	D	C	B	A	
4.7 cm	24.5 x 36 cm	6.3 cm	25 x 48 cm	60 cm	60 x 60 cm
4.7 cm	39.5 x 66 cm	6.3 cm	30 x 58 cm	70 cm	70 x 70 cm
4.7 cm	34.5 x 76 cm	6.3 cm	35 x 68 cm	80 cm	80 x 80 cm
4.7 cm	39.5 x 86 cm	6.3 cm	40 x 78 cm	90 cm	90 x 90 cm
4.7 cm	44.5 x 96 cm	6.3 cm	45 x 88 cm	100 cm	100 x 100 cm
4.7 cm	49.5 x 106 cm	6.3 cm	50 x 98 cm	110 cm	110 x 110 cm
4.7 cm	54.5 x 116 cm	6.3 cm	55x 108 cm	120 cm	120 x 120 cm



#### اغطية مناهل ثلاثة ابواب

ارتفاع القطعة الفولاذي	القطعة الفولاذي	ارتفاع الغيوم الخاربي	مقاسي فتحة الغيوم الخاربي	الغيوم الخاربي	الاصف
E	D	C	B	A	
4.7 cm	27 x 86 cm	6.3 cm	24 x 78 cm	90cm	90 x 90 cm
4.7 cm	30.5 x 96 cm	6.3 cm	27 x 88 cm	100 cm	100 x 100 cm
4.7 cm	37 x 116 cm	6.3 cm	34 x 108 cm	120 cm	120 x 120 cm



#### المواصفات الفنية:

البروفيلات: مصنوع من مادة الالمنيوم النقي من أفضل الشركات.  
الالواح مصنوعة من النقي انواع الالمنيوم وسماكة 2 ملم ومغلف من الاسفل بطبقة بلاستيك لحمايته من ظروف الاكسدة وابعرة المياه.  
الزبر: الفطاء له زبر مزدوج ومصنوع من مادة PDM ومقاوم للظروف الجوية.  
براغي الزاوية ستانلس ستيل.  
تم عملية الكبس والتصنيع للزوايا بنظام الكبس عالي الجودة واحداث الماكينات في العالم.  
الشبك حديد سماكة 2,3 ملم.

شركة المربع الفضي للتجارة والاستثمار - ذرية المربع - دكا - شارع دكا 5 - بعان الأردن - الهاتف: 064120096 - الفاكس: 064120097 - الجوال: 0799465339  
البريد الإلكتروني: silversquare1@outlook.com

- يتم تفصيل اي مقاس حسب الطلب -

Silver Square Trading &amp; Invs.

مصنع المربع الفضي  
SILVER SQUAREصنع في الأردن  
Elegant مناهل

Made In Jordan

MANHOLE COVERS					إغطية مناهل
الارتفاع الفولاذ الدامني	الفولاذ الدامني	ارتفاع القرم الخرساني	سماكة قشرة القرم الخرساني	القرم الخرساني	الصف
E	D	C	B	A	
3.5 Cm	17 Cm	4.7 Cm	10.0 Cm	20 Cm	20 * 20 Cm
3.5 Cm	27 Cm	4.7 Cm	20.0 Cm	30 Cm	30 * 30 Cm
3.5 Cm	37 Cm	4.7 Cm	30.0 Cm	40 Cm	40 * 40 Cm
3.5 Cm	47 Cm	4.7 Cm	40.0 Cm	50 Cm	50 * 50 Cm
3.5 Cm	57 Cm	4.7 Cm	50.0 Cm	60 Cm	60 * 60 Cm
3.5 Cm	67 Cm	4.7 Cm	60.0 Cm	70 Cm	70 * 70 Cm
3.5 Cm	77 Cm	4.7 Cm	70.0 Cm	80 Cm	80 * 80 Cm

MANHOLE COVERS					Model Luxury	إغطية مناهل
الارتفاع الفولاذ الدامني	الفولاذ الدامني	ارتفاع القرم الخرساني	سماكة قشرة القرم الخرساني	القرم الخرساني	الصف	
E	D	C	B	A		
3.5 Cm	47 Cm	4.7 Cm	40.0 Cm	50 Cm	50 * 50 Cm	
3.5 Cm	57 Cm	4.7 Cm	50.0 Cm	60 Cm	60 * 60 Cm	
3.5 Cm	67 Cm	4.7 Cm	60.0 Cm	70 Cm	70 * 70 Cm	

المواصفات الفنية:	
	<p>الزيفولات: مصنوع من مادة الألمنيوم النقي من أفضل الشركات.</p> <p>الألواح: مصنوعة من الفين أواي الألمنيوم وسماكة 5 ملم ومغطى من الأسفل بطبقة بلاستيكية لتحمايته من ظروف الأكسدة وانزعة المياه.</p> <p>الزبن الفولاذ: له زبن مزبوج ومصنوع من مادة POM ومقاوم للتآكل.</p> <p>مزايا الزاوية: متجانس سهل.</p> <p>أمر عملية الكبس والتجميع: الزوايا بنظام الكبس عالي الجودة وأحدث الماكينات في العالم.</p> <p>الشبكة: جديد سماكة 2.3 ملم.</p>
	
<p>شركة المربع الفضي للتجارة والصناعة - جدة - حي النور - ص.ب. 5 - ج.ب. 20096 - الرياض - 011-2209777 - التليفون 011-2209777 - الفاكس 011-2209777</p>	

المواصفات الفنية:	
	<p>الزيفولات: مصنوع من مادة الألمنيوم النقي من أفضل الشركات.</p> <p>الألواح: مصنوعة من الفين أواي الألمنيوم وسماكة 2 ملم ومغطى من الأسفل بطبقة بلاستيكية لتحمايته من ظروف الأكسدة وانزعة المياه.</p> <p>الزبن الفولاذ: له زبن مزبوج ومصنوع من مادة POM ومقاوم للتآكل.</p> <p>مزايا الزاوية: متجانس سهل.</p> <p>أمر عملية الكبس والتجميع: الزوايا بنظام الكبس عالي الجودة وأحدث الماكينات في العالم.</p> <p>الشبكة: جديد سماكة 2.3 ملم.</p>
	
<p>شركة المربع الفضي للتجارة والصناعة - جدة - حي النور - ص.ب. 5 - ج.ب. 20096 - الرياض - 011-2209777 - التليفون 011-2209777 - الفاكس 011-2209777</p>	



- يتم تفصيل اي مقاس حسب الطلب -



Silver Square Trading &amp; Invs.



مصنع المربع الفضي

Made In Jordan

صنع في الأردن

اغنية مناهل

MANHOLE FIBER		مناهل فايبر			
الوزن	C	B	A		الصف
4.1 ك	4 CM	22.4 CM	31.7 CM		30×30 CM
7 ك	3.4 CM	25.8 CM	40 CM		40×40 CM
12 ك	4 CM	37 CM	46.5 CM		50×50 CM
17 ك	5 CM	46.8 CM	57.5 CM		60×60 CM
23 ك	5.5 CM	58.3 CM	67 CM		70×70 CM
43 ك	6 CM	66 CM	80 CM		80×80 CM

الألوان المتوفرة : أسود ، سكري ، كرميدي ، بيج

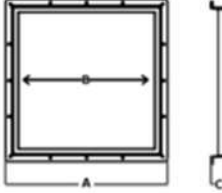
		<p><b>ملاحظات</b></p> <p>يتحمل لغاية وزن 5 طن إيادي الغطاء ستانلس ستيل</p>
<p>شركة المربع الفضي للتجارة والاستثمار - خربة السوق - جازا - شارع جازا 1 - عمان- الأردن - الهاتف: 064120096 - الفاكس: 064120097 - الجوال: 0799465339 البريد الإلكتروني: silversquare1@outlook</p>		

	
<p>جريل ألومنيوم مع سدة قوة التحمل 1.600 طن</p>	

	
<p>جريل ألومنيوم مع سدة قوة التحمل 2 طن</p>	

	
<p>جريل ألومنيوم مع سدة قوة التحمل 2 طن</p>	



Manhole covers are made Aluminium Sheets . These covers need to be heavy so that when vehicles drive over them, they do not become dislodged. Manhole covers normally weigh 100+ pounds each. Some have open pick holes which allow water to enter the manhole. Others have concealed pick holes which do not go all the way through the cover or lift handles such as drop handles or ring handles. Manhole covers can be bolted to the frame for security reasons. Manhole covers can also have a gasket on the bottom of the cover and bolted to the frame which is normally considered watertight.

### Ductile Iron Manhole Covers

The Ductile Iron Manhole Covers have exceptionally strong resistance against corrosion and rust. They have advanced molecular, excellent additional strength and shock load resistance. These can deal with heavy and fast moving traffic. Ductile Iron Manhole Covers allow for optimum speed and ease of access. They can replace the conventional alternatives. These have uniqueness and strength. These are the removable plates, used to cover the manholes and protecting them. Also, these prevent the person from falling into it. They are easy to handle and have more load bearing capacity.



About product:

- Aluminium Recessed Covers. The aluminium covers are odour and waterproof and available in multiple sizes and heights, depending on the application.
- Frame and cover are made of extruded aluminium profile and are easy to open with the lifting keys.
- Application: outdoor and Indoor
- Cover with the cover placed freely in the outer frame.
- Standard equipped with a Galvanized reinforcement mesh.
- 2 mm Aluminium Base plate.
- Two seals: one seal at the base and another rubber seal incorporated into the outer frame.
- The Out frame rubber seal has three functions:
  - It prevents dirt between the cover and the frame.
  - The rubber's elastic effect avoids tension between the cover and the frame.
  - It offers an additional smell barrier

**BS:EN124-3 2015 Standard.**



**Features:** Gas, smell, and waterproof. The cover has a double high-grade EPDM seal and there is a T rubber seal on the side of the frame to prevent dirt infiltration between frame and cover

**Applications:**

floor, road, driveway, garden, park, Industry, Construction and public use , Outdoor use for balconies, garage doors, patios

- Material : Extruded Aluminium Frame an6063/6082
- Bolts : Stainless Steel
- Revit's : Aluminium
- Wire Mesh : Galvanized Steel
- Height : 50-60 mm ( and can be More depending on project requirements )
- Recess Depth :40-50 mm or as required by project
- Type of Seal : EPDM Double Seal
- Load Type : Medium/ Heavy Duty

**Description:**

- Aluminium recessed cover is a smell and waterproof aluminium inspection cover. The inspection covers are expertly provided with two seals: two seals at the base and the side of the frame .
- High quality, strong, resistant and recyclable Double sealed aluminium recessed access covers. Available in 40, 60 and 80mm depths, they are suitable for outdoor and indoor use, in areas where a superior finish is required.
- Aluminium are available in different heights: 55mm – 80mm – 100mm. This makes it easy for the contractor to select the right inspection cover for each application.
- The Double Seal aluminium accessed covers offer a superior finish for a wide range of flooring finishes. Available in frame depths of 40, 60 and 80mm and tray depths starting at 27mm.
- Designed with a narrow frame width to offer a near seamless edge, providing an aesthetically pleasing finish. The tray depths provide compatibility with nearly all infill materials, including popular porcelain paving, which has seen a huge surge in demand.
- The strong, corrosion-resisting aluminium finish blends seamlessly with its environment. With a neoprene Double seal any risk of odours escaping the chamber is removed, while limiting ingress of any dirt or water from entering the chamber. Minimising any unseen issues from occurring below.
- All covers come ready packed with threaded keys for easy lifting through screw holes. Contractors can rely on the range for both internal and outdoor applications, including patios, driveways, and conservatories in residential applications as well as education, health, leisure, and retail sectors.

**General :**

- Self-secured by the weight of the infill
- Lifting holes covered with plastic caps
- Recommended for exterior applications
- Extruded aluminum frame and easy to open
- The cover is odor and waterproof

## **Aluminium Manhole Covers Applications**

- Residential - patios, driveways, conservatories
- Retail - shops and shopping precincts, car showrooms
- Hotels
- Hospitals
- Kitchens
- Light commercial delivery areas
- Stations and airports
- Schools
- Sports and leisure facilities
- Villas and walkways



## Aluminium Alloy 6063 Technical Data Sheet

### Aluminum Alloy 6063

Aluminum alloy 6063 is a medium strength alloy commonly referred to as an architectural alloy. It is normally used in intricate extrusions.

It has a good surface finish, high corrosion resistance, is readily suited to welding and can be easily anodized. Most commonly available as T6 temper, in the T4 condition it has good formability.

#### Applications :6063 is typically used in:

Architectural applications  
Extrusions  
Window frames  
Doors  
Shop fittings  
Irrigation tubing

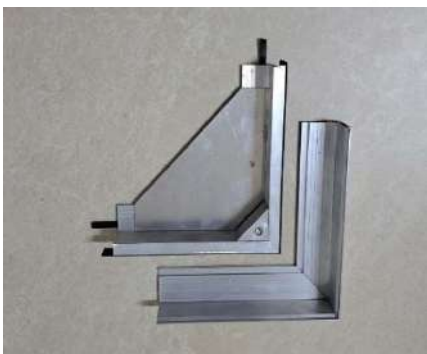

## Aluminum Manhole Frame and cover components

### Key Features of Our Aluminium Covers :

- Easy to open with two lifting keys included
- Waterproof & Odour proof
- EPDM seal with “T-rubber” seal
- Aluminium frame & cover
- Reinforcement mesh included with the cover

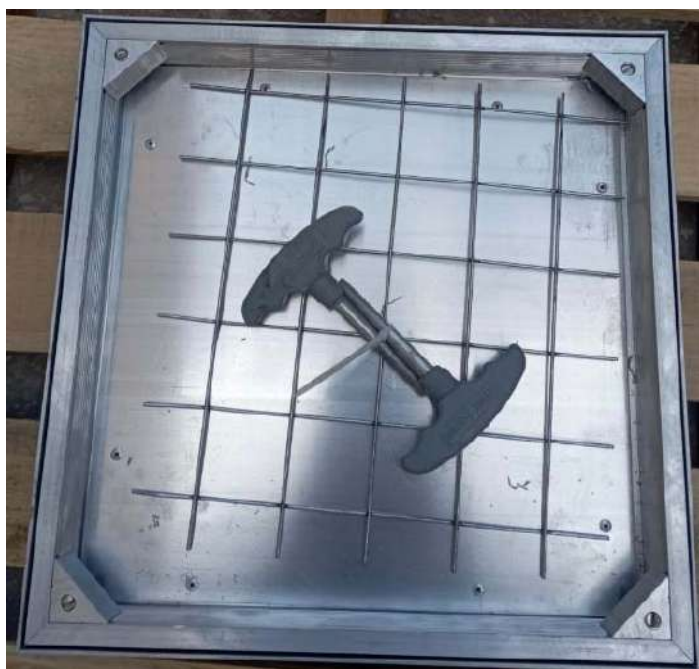

## LEFTING KEY

- Lifting Keys Included
- These manhole covers are supplied with two lifting keys as standard meaning you will not need any additional tools or components to remove these covers once fitted. These keys are galvanised making them corrosion resistant and will remain durable over long periods of time.
- These keys are used by simply removing the plastic dust cap, using the un-threaded end to remove the bolt from the keyhole, then swapping to the threaded end to screw into the cover.





## REINFORCED WIRE MESH

- **Reinforcement Mesh For Added Rigidity**

To improve the structural integrity of the cover once filled with your infill of choice, they are supplied with a reinforcement mesh which increases the load-bearing resistance of the cover infill. Many cheaper infill and recessed manhole covers do not have this feature making them less suited to areas with high loads.





## EPDM DOUBLE SEAL RUBBER

Aluminium Cover Double seal are the perfect choice for areas where an aesthetically pleasing inspection cover is required. The recessed top allows grass or block pavers to be installed blending in with the surrounding area. Available in both a double sealed configuration these access covers keep odours locked below ground level, this is ideal if covers are close to areas with high foot traffic. This odour locking system makes these covers especially well suited to patios and driveways. The seals used on these aluminium covers are made from 99.9% pure EPDM, ensuring it stands the test of time.

These aluminium recessed access covers are available in a wide range of sizes and depths giving you great flexibility when installing. Starting at 300x300mm, clear opening sizes go up to 1000x1000mm and many in between, we should have a cover to suit your needs

- Rubber Seals To Stop Odour Leakage

To keep these covers waterproof and odour proof, they have been linked with an elasticated rubber seal built into the side of the outer frame. This seal allows for reduced tension and prevention of dirt ingress between the cover and frame. This in turn reduces any unwanted odours from escaping the manhole.

### Double Seal EPDM Rubber is Placed in Track



## Channel Grating

- Channel Grating 73.5cm x 32.5 Cm outer dimension Medium Duty
- Test Load 13.0 Tons as Per ACES ( Arab Centre Labs ) as shown in test report
- Material : Aluminium Channel and Frame
- Serrated grating provides maximum slip resistance.
- Aluminum grating is more corrosion resistant Plus, it's lightweight, non sparking, and nonmagnetic.
- USE Used for the collection and drainage of rainwater. The matching to its pre-mounted grating allows the use in pedestrian or light traffic areas.





**HITECH METAL FORMING**

**The Edge Of Innovation**

***HITECH METAL FORMING***

***AJMAN - UNITED ARAB EMIRATES***

**Emirates Office :**  
**Tel : 00971 -5693 59 799**

**Qatar Office :**  
**Tel : 00974 -66863386**  
**00974 50403055**

**Jordan Office :**  
**Tel : 00962 79 5556542**

**Emails : [info@hitechmf.com](mailto:info@hitechmf.com) , [sales@hitechmf.com](mailto:sales@hitechmf.com) , [farook@hitechmf.com](mailto:farook@hitechmf.com)**

**[www.hitechmf.com](http://www.hitechmf.com)**